

CE EMC TEST REPORT

for

Product: CEILING FAN WITH LIGHTS - WITH BLUETOOTH

Model: 001 038 300100 00 00, 001 038 300102 00 00, 001 038 300104 00 00

Report No.: KEYS240801018002EM-02

Issued for

Mutlusan Plastik Elektrik San. Tic. A.Ş.

i0SB mahallesi Enkoop caddesi No:7 Basaksehir /istanbul/Türkiye

Issued by

Guangdong KEYS Testing Technology Co.,Ltd.

**Address: Building 1, No.18, Shihuan Road, Dongcheng Subdistrict, Dongguan,
Guangdong, China**

104, No.4, Fumin Street, Shilong, Dongguan, Guangdong, China

Note: This report shall not be reproduced except in full, without the written approval of Guangdong KEYS Testing Technology Co., Ltd. This document may be altered or revised by Guangdong KEYS Testing Technology Co., Ltd. personnel only, and shall be noted in the revision section of the document. The test results presented in this report only relate to the tested sample



TABLE OF CONTENTS

1. TEST CERTIFICATION	3
2. TEST SUMMARY	4
3. TEST SITE	5
3.1. TEST FACILITY	5
3.2. MEASUREMENT UNCERTAINTY	5
3.3. LIST OF TEST AND MEASUREMENT INSTRUMENTS	5
4. EUT DESCRIPTION	9
5. TEST METHODOLOGY	10
5.1. TEST MODE	10
5.2. EUT SYSTEM OPERATION	10
6. SETUP OF EQUIPMENT UNDER TEST	11
6.1. DESCRIPTION OF SUPPORT UNITS	11
6.2. CONFIGURATION OF SYSTEM UNDER TEST	11
7. EMISSION TEST	12
7.1. CONDUCTED EMISSION MEASUREMENT	12
7.2. RADIATED ELECTROMAGNETIC DISTURBANCE	16
7.3. RADIATED EMISSION MEASUREMENT	21
7.4. HARMONICS CURRENT MEASUREMENT	25
7.5. VOLTAGE FLUCTUATION AND FLICKS MEASUREMENT	32
8. IMMUNITY TEST	34
8.1. GENERAL DESCRIPTION	34
8.2. GENERAL PERFORMANCE CRITERIA DESCRIPTION	35
8.3. ELECTROSTATIC DISCHARGE (ESD)	36
8.4. RADIATED, RADIO-FREQUENCY, ELECTROMAGNETIC FIELD (RS)	39
8.5. ELECTRICAL FAST TRANSIENT (EFT)	42
8.6. SURGE IMMUNITY TEST	44
8.7. CONDUCTED RADIO FREQUENCY DISTURBANCES (CS)	46
8.8. POWER FREQUENCY MAGNETIC FIELD	48
8.9. VOLTAGE DIP & VOLTAGE INTERRUPTIONS	50
9. PHOTOGRAPHS OF THE TEST CONFIGURATION	52
10. PHOTOGRAPHS OF EUT	54

1. TEST CERTIFICATION

Product:	CEILING FAN WITH LIGHTS - WITH BLUETOOTH
Trade mark:	
Model:	001 038 300100 00 00, 001 038 300102 00 00, 001 038 300104 00 00
Applicant :	Mutlusan Plastik Elektrik San. Tic. A.Ş.
Address:	i0SB mahallesi Enkoop caddesi No:7 Basaksehir /istanbul/Türkiye
Manufacturer:	Mutlusan Plastik Elektrik San. Tic. A.Ş.
Address:	i0SB mahallesi Enkoop caddesi No:7 Basaksehir /istanbul/Türkiye
Test Date:	August 4, 2024 to August 8, 2024
Issued Date:	August 8, 2024
Test Voltage:	230VAC 50 Hz Light Power:36W Fan Power:30W Speaker Power:5W
Applicable Standards:	EMC Directive 2014/30/EU EN IEC 55015:2019+A11:2020 EN IEC 61547:2023 EN IEC 61000-3-2:2019+A1:2021 EN 61000-3-3:2013+A1:2019+A2:2021

The above equipment has been tested by Guangdong KEYS Testing Technology Co., Ltd. and found compliance with the requirements in the technical standards mentioned above. The test results presented in this report only relate to the product/system tested. The Other similar equipment will not necessarily produce the same results due to production tolerance and measurement uncertainties.

Test Engineer:

Technical Manager:

Linda Chen / Engineer

Summer Xia / Manager

2. TEST SUMMARY

EMISSION			
Standard	Item	Result	Remarks
EN IEC 55015:2019+A11:2020	Conducted (Main Port)	PASS	Complied with limit
	Radiated Electromagnetic Disturbance	PASS	Complied with limit
	Radiated Emission	PASS	Complied with limit
EN IEC 61000-3-2:2019+A1:2021	Harmonic current emissions	PASS	Complied with limit
EN 61000-3-3:2013+A1:2019+A2:2021	Voltage fluctuations & flicker	PASS	Complied with limit

IMMUNITY			
Standard	Item	Result	Remarks
EN 61000-4-2:2009	ESD	PASS	Complied with the requirements
EN IEC 61000-4-3:2020	RS	PASS	Complied with the requirements
EN 61000-4-4:2012	EFT	PASS	Complied with the requirements
EN 61000-4-5:2014 +A1:2017	Surge	PASS	Complied with the requirements
EN IEC 61000-4-6:2023	CS	PASS	Complied with the requirements
EN 61000-4-8:2010	PFMF	N/A	N/A
EN IEC 61000-4-11:2020	Voltage dips & voltage variations	PASS	Complied with the requirements

Note: 1) The test result verdict is decided by the limit of test standard

2) The information of measurement uncertainty is available upon the customer's request.

3. TEST SITE

3.1. TEST FACILITY

Guangdong KEYS Testing Technology Co., Ltd.
 Building 1, No.18, Shihuan Road, Dongcheng Subdistrict, Dongguan, Guangdong, China
 104, No.4, Fumin Street, Shilong, Dongguan, Guangdong, China

3.2. MEASUREMENT UNCERTAINTY

Parameter	Uncertainty
Temperature	$\pm 1^{\circ} \text{ C}$
Humidity	$\pm 5\%$
DC and Low Frequency Voltages	$\pm 3\%$
Conducted Emission(150KHz-30MHz)	$\pm 3.60\text{dB}$
Radiated Emission(30MHz-1GHz)	$\pm 4.76\text{dB}$
Radiated Emission (1GHz-18GHz)	$\pm 4.44\text{dB}$

Note 1: This uncertainty represents an expanded uncertainty expressed at approximately the 95% confidence level using a coverage factor of k=2.

3.3. LIST OF TEST AND MEASUREMENT INSTRUMENTS

3.3.1. For conducted emission at the mains terminals test

Name of Equipment	Manufacturer	Model	Serial No.	Calibration Due
EMI Test Receiver	Rohde&Schwarz	ESCI7	KEYS-E-005	July 1, 2025
Pulse limiter	Rohde&Schwarz	ESH3-Z2	KEYS-E-003	July 1, 2025
LISN impedance network TWO-LINE V-WORK	Rohde&Schwarz	ENV216	KEYS-E-004	July 1, 2025
Screened room	AUDIX	6*3*3	KEYS-E-001	July 1, 2025

3.3.2. For radiated electromagnetic emission test

Name of Equipment	Manufacturer	Model	Serial No.	Calibration Due
EMI Test Receiver	Rohde&Schwarz	ESCI7	KEYS-E-005	July 1, 2025
Triple-Loop Antenna	PATCH PANEL	RF300	KEYS-EE-033	Sep. 17, 2024

3.3.3. For radiated emission test (30MHz-1GHz)

Name of Equipment	Manufacturer	Model	Serial No.	Calibration Due
EMI Test Receiver	Rohde&Schwarz	ESCI7	KEYS-E-005	July 1, 2025
Composite antenna	Schwarzbeck	VULB9168	KEYS-E-013	July 9, 2025
Preamplifier	AUDIX	EM330	KEYS-E-014	July 1, 2025
3m standard semi-anechoic chamber	AUDIX	9*6*6	KEYS-E-002	July 1, 2025

3.3.4. For harmonic current emissions and voltage fluctuations/flicker test

Name of Equipment	Manufacturer	Model	Serial No.	Calibration Due
Harmonics / Flicker Test System	DCUU INSTRUMENT CO., LTD.	KDF-11005G	KEYS-E-017	July 1, 2025
AC Power Source	DCUU INSTRUMENT CO., LTD.	BADT002-11	KEYS-E-025	Aug.23,2024

3.3.5. For electrostatic discharge immunity test

Name of Equipment	Manufacturer	Model	Serial No.	Calibration Due
ESD Generator	Shanghai Lingshi Electronics Co., LTD	ESD-203A	KEYS-E-023	July 2, 2025

3.3.6. For radio frequency electromagnetic field immunity (R/S) test (DQT)

Name of Equipment	Manufacturer	Model	Serial No.	Calibration Due
Signal Generator	Agilent	N517113-50B	KEYS-EE-038	Sep. 17, 2024
Amplifier	A&R	150W1000M3	KEYS-EE-039	Sep. 17, 2024
Amplifier	A&R	50SIG6M2	KEYS-EE-040	Sep. 17, 2024
Antenna	SCHWARZBECK	STLP9149	KEYS-EE-046	Sep. 17, 2024
Isotropic Field Probe	A&R	FL7006	KEYS-EE-049	Sep. 17, 2024
Log-periodic Antenna	SCHWARZBECK	STLP 9128E	KEYS-EE-042	Sep. 17, 2024

3.3.7. For electrical fast transient/burst immunity test

Name of Equipment	Manufacturer	Model	Serial No.	Calibration Due
EFT Tester	HTEC	HEFT 51	KEYS-EE-051	Sep. 17, 2024
EFT Coupling Clamp	HTEC	HEFT 51-C	KEYS-EE-053	Sep. 17, 2024

3.3.8. For surge immunity test

Name of Equipment	Manufacturer	Model	Serial No.	Calibration Due
Lightning surge generator	Shanghai Prima Electronics Co., LTD	SUG61005TB-221 6	KEYS-E-030	July 2, 2025

3.3.9. For injected currents susceptibility test

Name of Equipment	Manufacturer	Model	Serial No.	Calibration Due
C/S Test System	SCHLODER	CDG-6000-25	KEYS-EE-056	Sep. 17, 2024
Coupling Decoupling Network	SCHLODER	CDN-M2+3	KEYS-EE-059	Sep. 17, 2024



Report No: KEYS240801018002EM-02

Electromagnetic Injection Clamp	Luthi	EM101	KEYS-EE-066	Sep. 17, 2024
---------------------------------	-------	-------	-------------	---------------

3.3.10. For power frequency magnetic field immunity test

Name of Equipment	Manufacturer	Model	Serial No.	Calibration Due
Magnetic Field Tester	HTEC	HPFMF	KEYS-EE-068	Sep. 17, 2024

3.3.11. For voltage dips and short interruptions immunity test

Name of Equipment	Manufacturer	Model	Serial No.	Calibration Due
Dips Tester	HTEC	HPFS	KEYS-EE-067	Sep. 17, 2024



4. EUT DESCRIPTION

Product	CEILING FAN WITH LIGHTS - WITH BLUETOOTH
Model	001 038 300100 00 00
Supplied Voltage	230VAC 50 Hz
Power	Light Power:36W Fan Power:30W Speaker Power:5W

I/O PORT

I/O PORT TYPES	Q'TY	TESTED WITH
AC Port	1	<input checked="" type="checkbox"/>
DC Port	1	<input type="checkbox"/>

Models Difference

All series models are identical, except for model name difference for trading purpose.

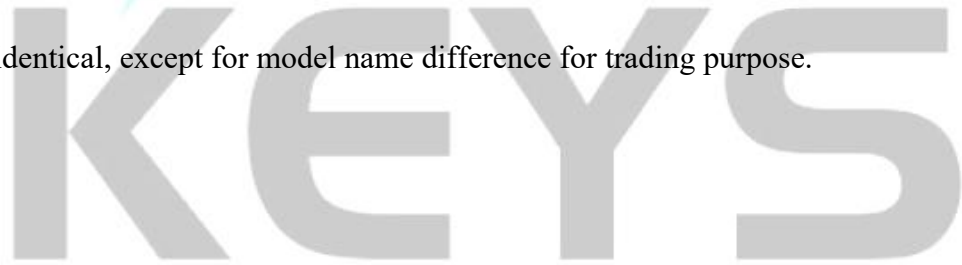

5. TEST METHODOLOGY

5.1. TEST MODE

The EUT was tested together with the thereafter additional components, and a configuration, which produced the worst emission levels, was selected and recorded in this report.

The following test mode(s) were assessed.

	Test Items	Test Mode
Emission	Conducted Emission	Lighting
	Radiated Electromagnetic Disturbance	Lighting
	Radiated Emission	Lighting
	Harmonic current emissions	Lighting
	Voltage fluctuations & flicker	Lighting
Immunity	ESD	Lighting
	RS	Lighting
	EFT	Lighting
	Surge	Lighting
	C/S	Lighting
	M/S	N/A
	Dips	Lighting

5.2. EUT SYSTEM OPERATION

1. Set up EUT with the support equipment.
2. Make sure the EUT work normally during the test.

6. SETUP OF EQUIPMENT UNDER TEST

6.1. DESCRIPTION OF SUPPORT UNITS

The EUT has been tested as an independent unit together with other necessary accessories or support units. The following support units or accessories were used to form a representative test configuration during the tests.

No.	Equipment	Model	Serial No.	FCC ID	Trade Name	Data Cable	Power Cord
1.	N/A	N/A	N/A	N/A	N/A	N/A	N/A

- Note: 1) All the equipment/cables were placed in the worst-case configuration to maximize the emission during the test.
 2) Grounding was established in accordance with the manufacturer’s requirements and conditions for the intended use.

6.2. CONFIGURATION OF SYSTEM UNDER TEST

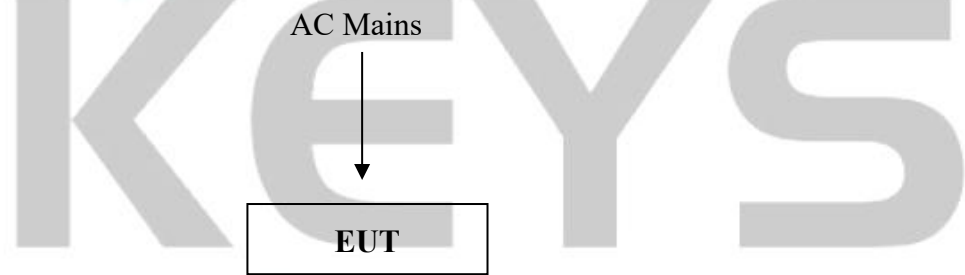

(EUT: CEILING FAN WITH LIGHTS - WITH BLUETOOTH)

7. EMISSION TEST

7.1. CONDUCTED EMISSION MEASUREMENT

7.1.1. LIMITS

FREQUENCY (MHz)	LIMITS(dB V)	
	Quasi-peak	Average
0.009-0.05	110	N/A
0.05-0.15	90 – 80	N/A
0.15 - 0.5	66 – 56	56 - 46
0.50 - 5.0	56	46
5.0 - 30.0	60	50

Note: 1) The lower limit shall apply at the transition frequencies.

2) The limit decreases in line with the logarithm of the frequency in the range of 0.15 MHz to 0.5 MHz

7.1.2. TEST PROCEDURES

The EUT and Support equipment, if needed, was set up as per the test configuration to simulate typical usage per the user's manual. When the EUT is a tabletop system, a wooden table with a height of 0.8 meters is used and is placed on the ground plane. When the EUT is floor standing equipment, it is placed on the ground plane, which has a 3-12 mm non-conductive covering to insulate the EUT from the ground plane. The EUT should be 0.8 m apart from the AMN, where the mains cable supplied by the manufacturer is longer than 0.8 m, the excess should be folded at the centre into a bundle no longer than 0.4 m, Details please refer to test setup photography.

The Receiver scanned from 9 kHz to 30 MHz for emissions in each of the test modes. During the above scans, the emissions were maximized by cable manipulation.

A scanning was taken on the power lines, Line and neutral, recording at least six highest emissions. Emission frequency and amplitude were recorded into a computer in which correction factors were used to calculate the emission level and compare reading to the applicable limit. The test data of the worst-case condition(s) was recorded.

Note: Test Software Name: e3, Software Version: 1.0.0.0.

7.1.3. TEST SETUP

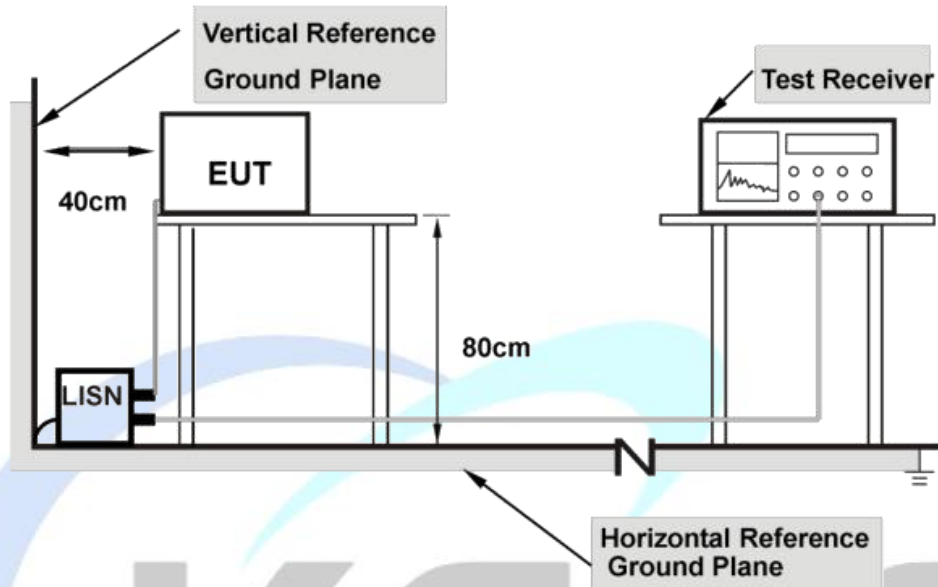

Note: 1.Support units were connected to second LISN.

2.Both of LISNs(AMN) are 80 cm from EUT and at least 80 from other units and other metal planes

7.1.4. TEST RESULT

Product name	CEILING FAN WITH LIGHTS - WITH BLUETOOTH	Tested By	Brian
Model	001 038 300100 00 00	Detector Function	Peak / Quasi-peak/AV
Test Mode	Lighting	6 dB Bandwidth	200 Hz/9 kHz
Environmental Conditions	24.3 °C, 54.1 % RH, 101.1 kPa	Test Result	Pass

Note:

L = Line Line, N = Neutral Line

Freq. = Emission frequency in MHz

Reading level (dB V) = Receiver reading

Corr. Factor (dB) = attenuator + Cable loss

Level (dB V) = Reading level (dB V) + Corr. Factor (dB)

Limit (dB V) = Limit stated in standard

Over Limit (dB) = Level (dB V) – Limit (dB V)

QP = Quasi-Peak

AV = Average

Please refer to the following diagram:

Line:

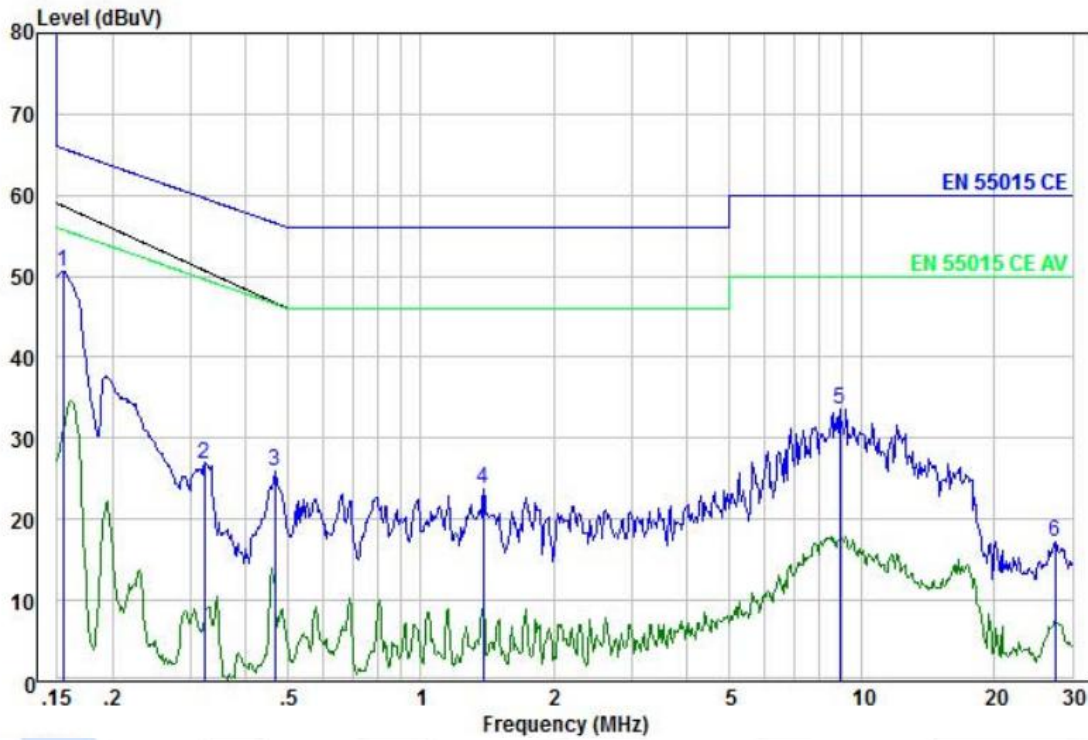

	Freq	Level	Read Level	Factor	Limit Line	Over Limit	LISN Factor	Cable Loss	Remark
	MHz	dBuV	dBuV	dB	dBuV	dB	dB	dB	
1	0.15	50.61	31.01	19.60	65.74	-15.13	9.60	10.00	Peak
2	0.32	26.71	7.11	19.60	59.62	-32.91	9.60	10.00	Peak
3	0.47	25.94	6.34	19.60	56.58	-30.64	9.60	10.00	Peak
4	1.39	23.79	4.29	19.50	56.00	-32.21	9.50	10.00	Peak
5	8.92	33.60	13.93	19.67	60.00	-26.40	9.67	10.00	Peak
6	27.42	17.33	-3.26	20.59	60.00	-42.67	10.59	10.00	Peak

Neutral:

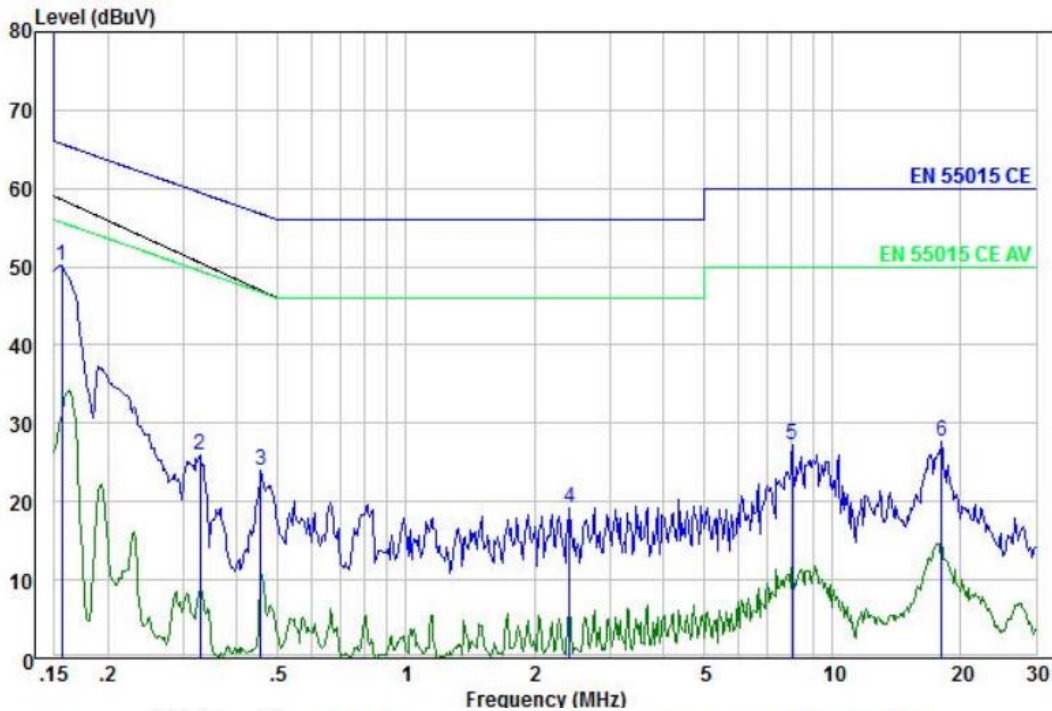

	Freq	Level	Read	Limit	Over	LISN	Cable	Remark
	MHz	dBuV	Level	Line	Limit	Factor	Loss	
			dBuV	dB	dBuV	dB	dB	
1	0.16	50.10	30.60	19.50	65.69	-15.59	9.50	10.00 Peak
2	0.33	26.01	6.51	19.50	59.49	-33.48	9.50	10.00 Peak
3	0.46	23.92	4.42	19.50	56.76	-32.84	9.50	10.00 Peak
4	2.42	19.21	-0.22	19.43	56.00	-36.79	9.43	10.00 Peak
5	8.06	27.25	7.51	19.74	60.00	-32.75	9.74	10.00 Peak
6	18.04	27.69	7.50	20.19	60.00	-32.31	10.19	10.00 Peak

7.2. RADIATED ELECTROMAGNETIC DISTURBANCE

7.2.1. LIMITS

Frequency	Limits for loop diameter dB(A)*		
	2 m	3 m	4 m
9 kHz-70 kHz	88	81	75
70 kHz-150 kHz	88-58**	81-51**	75-45**
150 kHz-3.0 MHz	58-22**	51-15**	45-9**
3.0 MHz-30 MHz	22	15-16***	9-12***

* At the transition frequency, the lower limit applies.
 ** Decreasing linearly with the logarithm of the frequency.
 *** Increasing linearly with the logarithm of the frequency.

7.2.2. TEST PROCEDURE

The EUT and support equipment are positioned in the centre of loop antenna system (LAS). The LAS consists of three circular, mutually perpendicular large-loop antennas (LLAs), having a diameter of 2 m, supported by a non-metallic base. A 50 Ω coaxial cable between the current probe of an LLA and the coaxial switch, and between this switch and the measuring equipment, shall have surface transfer impedance smaller than 10 m Ω /m at 100 kHz and 1 m Ω /m at 10 MHz. The distance between the outer diameter of the loop antenna system and nearby objects, such as floor and walls, shall be at least 0.5 m as per CISPR 15/ EN 55015.

The induced current in the loop antenna is measured by means of a current probe (1 V/A) and the CISPR measuring receiver. By means of a coaxial switch, the three field directions (X, Y, Z) can be measured in sequence.

The receiver scanned from 9 kHz to 30 MHz for emissions in each of the test modes, and recorded at least the six highest emissions. Each value shall comply with the requirement given.

The test data of the worst-case condition(s) was recorded.

Note: Test Software Name: e3, Software Version: 1.0.0.0.

7.2.3. TEST SETUP

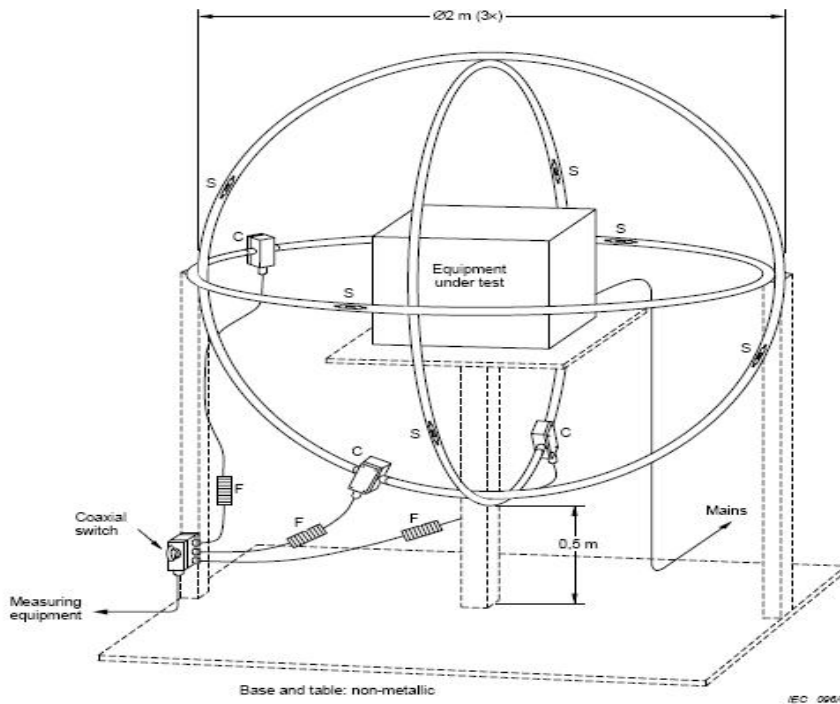

For the actual test configuration, please refer to the related item – Photographs of the Test Configuration.

7.2.4. TEST RESULT

Product name	CEILING FAN WITH LIGHTS - WITH BLUETOOTH	Antenna Pole	X, Y, Z
Model	001 038 300100 00 00	Antenna Diameter	2 m
Test Mode	Lighting	Detector Function	Peak
Environmental Conditions	24.3°C, 54.1 % RH, 101.1 kPa	6 dB Bandwidth	200 Hz/9 kHz
Tested By	Brian	Test Result	Pass

Note:

Freq. = Emission frequency in MHz

Reading level (dB A) = Receiver reading

Corr. Factor (dB) = Antenna factor + Cable loss

Measurement (dB A) = Reading level (dB A) + Corr. Factor (dB)

Limit (dB A) = Limit stated in standard

Over Limit (dB) = Measurement (dB A) – Limit (dB A) QP = Quasi-Peak

Please refer to the following diagram:

X:



No.	Frequency (MHz)	Reading Level(dBuA)	Factor (dB)	Measurement(dBuA)	Limit (dBuA)	Over (dB)	Detector	Comment
1	0.1779	3.34	10.48	13.82	55.94	-42.12	peak	
2	0.2199	4.48	10.47	14.95	53.40	-38.45	peak	
3	0.3462	4.33	10.43	14.76	47.94	-33.18	peak	
4	0.4858	0.32	10.39	10.71	43.87	-33.16	peak	
5	0.7780	-5.74	10.44	4.70	38.22	-33.52	peak	
6	1.3851	-8.04	10.44	2.40	31.29	-28.89	peak	

Y:



No.	Frequency (MHz)	Reading Level(dBuA)	Factor (dB)	Measurement(dBuA)	Limit (dBuA)	Over (dB)	Detector	Comment
1	0.2671	5.41	10.45	15.86	51.06	-35.20	peak	
2	0.3180	1.94	10.44	12.38	48.96	-36.58	peak	
3	0.5340	2.35	10.40	12.75	42.74	-29.99	peak	
4	0.9020	-1.28	10.46	9.18	36.44	-27.26	peak	
5	1.0220	-4.90	10.48	5.58	34.94	-29.36	peak	
6	1.4254	-9.66	10.43	0.77	30.94	-30.17	peak	

Z:



No.	Frequency (MHz)	Reading Level (dBuA)	Factor (dB)	Measurement (dBuA)	Limit (dBuA)	Over (dB)	Detector	Comment
1	0.2058	7.33	10.47	17.80	54.19	-36.39	peak	
2	0.2898	3.40	10.45	13.85	50.08	-36.23	peak	
3	0.4737	1.04	10.40	11.44	44.18	-32.74	peak	
4	0.5897	1.25	10.41	11.66	41.54	-29.88	peak	
5	0.7700	-3.96	10.44	6.48	38.34	-31.86	peak	
6 *	1.0820	-4.11	10.47	6.36	34.25	-27.89	peak	

7.3. RADIATED EMISSION MEASUREMENT

7.3.1. LIMITS

FREQUENCY (MHz)	Limit (dB V/m) (At 3 m)	Limit (dB V/m) (At 10 m)
30 ~ 230	40	30
230 ~ 300	47	37

Note: 1) The lower limit shall apply at the transition frequencies.

2) Emission level (dB V/m) = 20 log Emission level (V/m).

7.3.2. TEST PROCEDURE

The equipment was set up as per the test configuration to simulate typical usage per the user's manual. When the EUT is a tabletop system, a wooden turntable with a height of 0.8 meters is used which is placed on the ground plane. When the EUT is floor standing equipment, it is placed on the ground plane which has a 3-12 mm non-conductive covering to insulate the EUT from the ground plane.

The antenna was placed at 3 meter away from the EUT. The antenna connected to the spectrum analyzer via a cable and at times a pre-amplifier would be used.

The analyzer / receiver quickly scanned from 30 MHz to 300 MHz. The EUT test program was started. Emissions were scanned and measured rotating the EUT to 360 degrees and positioning the antenna 1 to 4 meters above the ground plane, in both the vertical and the horizontal polarization, to maximize the emission reading level.

During the above scans, the emissions were maximized by cable manipulation. Each modes is measured, recorded at least the six highest emissions. Emission frequency, amplitude, antenna position, polarization and turntable position were recorded into a computer in which correction factors were used to calculate the emission level and compare reading to the applicable limit and only Q.P. reading is presented.

The test data of the worst-case condition(s) was recorded.

Note: Test Software Name: e3, Software Version: 8.2.1.0.

7.3.3. TEST SETUP

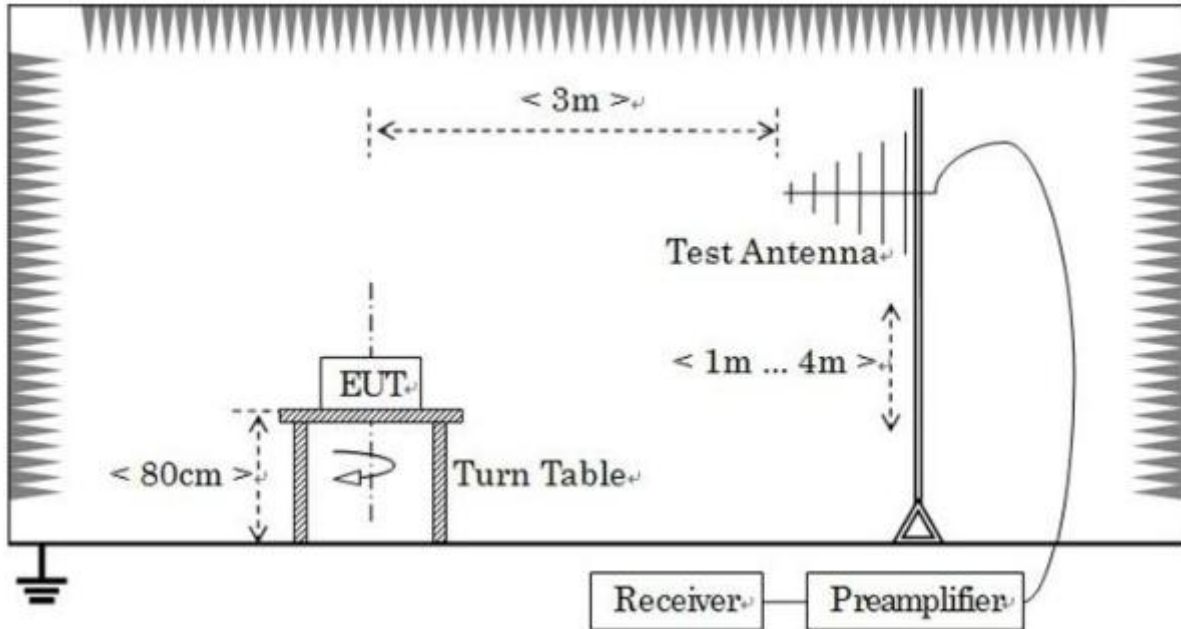

Note: For the actual test configuration, please refer to the related item – Photographs of the Test Configuration

7.3.4. TEST RESULT

Product name	CEILING FAN WITH LIGHTS - WITH BLUETOOTH	Antenna Distance	3 m
Model	001 038 300100 00 00	Antenna Pole	Vertical / Horizontal
Test Mode	Lighting	Detector Function	Peak / Quasi-peak
Environmental Conditions	24.3 °C, 54.1 % RH, 101.1 kPa	6 dB Bandwidth	120 kHz
Tested by	Brian	Test Result	Pass

Note:

Freq. = Emission frequency in MHz

Reading level (dB V) = Receiver reading (dB V)

Corr. Factor (dB/m) = Antenna factor (dB/m) + Cable loss (dB) - Preamp Factor (dB)

Measurement (dB V/m) = Reading level (dB V) + Corr. Factor (dB/m)

Limit (dB V/m) = Limit stated in standard

Over Limit (dB) = Measurement (dB V/m) - Limit (dB V/m)

QP = Quasi-Peak



Please refer to the following diagram:

Vertical:

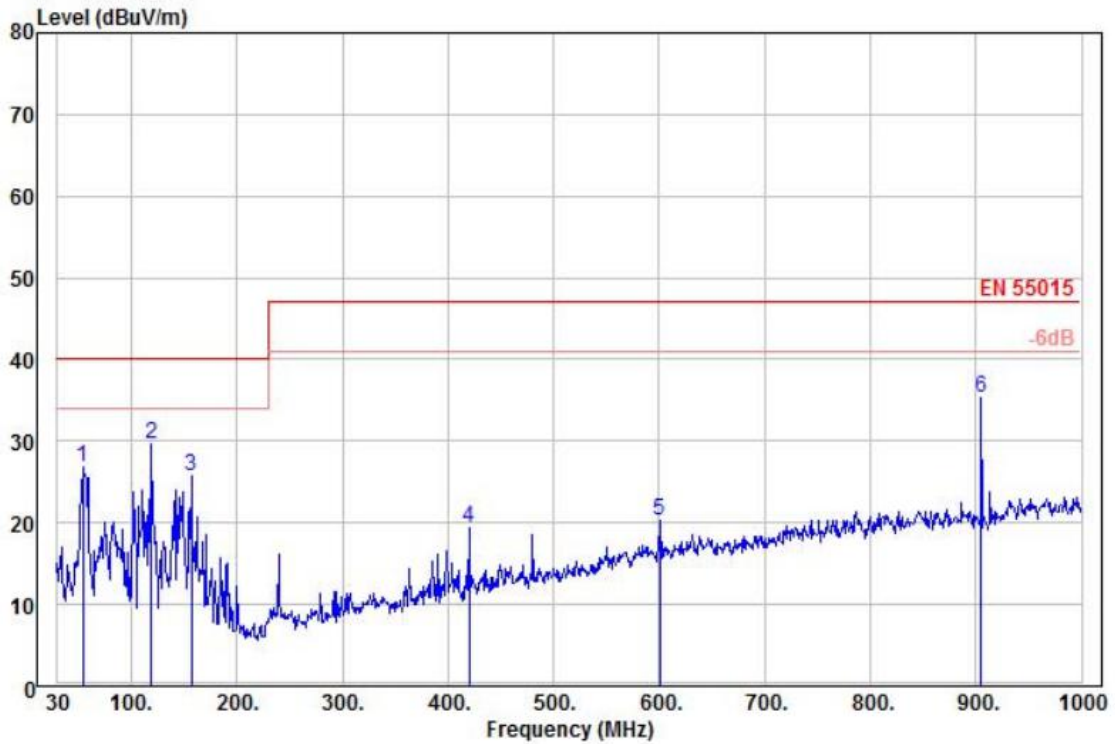

	Freq	Level	Read Level	Factor	Limit Line	Over Limit	Ant Factor	Cable Loss	Remark
	MHz	dBuV/m	dBuV	dB/m	dBuV/m	dB	dB/m	dB	
1	54.25	26.89	43.79	-16.90	40.00	-13.11	12.97	0.58	Peak
2	119.24	29.62	48.36	-18.74	40.00	-10.38	11.00	0.80	Peak
3	157.07	25.78	41.78	-16.00	40.00	-14.22	13.65	0.92	Peak
4	419.94	19.38	32.23	-12.85	47.00	-27.62	15.79	1.52	Peak
5	600.36	20.21	28.79	-8.58	47.00	-26.79	19.34	1.88	Peak
6	904.94	35.41	38.69	-3.28	47.00	-11.59	23.70	2.31	Peak

Horizontal:

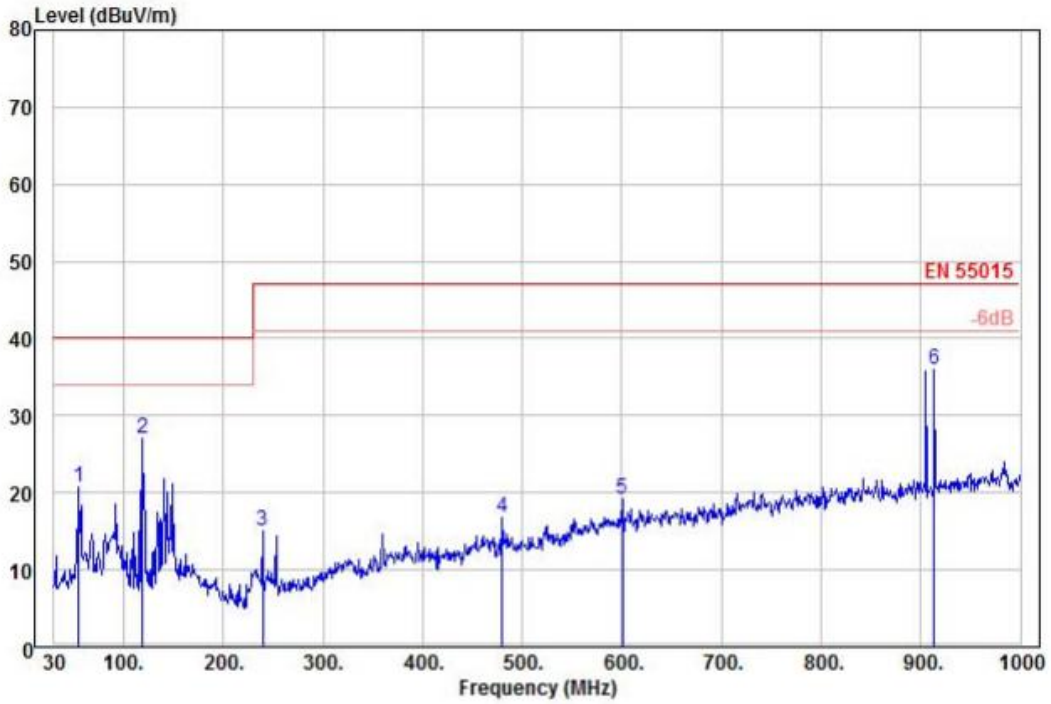

	Freq	Level	Read	Limit	Over	Ant	Cable	Remark
	MHz	dBuV/m	Level	Line	Limit	Factor	Loss	
			dBuV	dB/m	dBuV/m	dB	dB	
1	55.22	20.81	37.60	-16.79	40.00	-19.19	13.07	0.59 Peak
2	119.24	27.02	45.76	-18.74	40.00	-12.98	11.00	0.80 Peak
3	239.52	14.95	33.41	-18.46	47.00	-32.05	10.70	1.14 Peak
4	480.08	16.89	28.10	-11.21	47.00	-30.11	17.20	1.63 Peak
5	600.36	19.25	27.83	-8.58	47.00	-27.75	19.34	1.88 Peak
6	913.67	35.96	39.64	-3.68	47.00	-11.04	23.27	2.32 Peak

7.4. HARMONICS CURRENT MEASUREMENT

7.4.1. LIMITS OF HARMONICS CURRENT MEASUREMENT

Limit for Class A equipment		Limit for Class D equipment		
Harmonics Order N	Max. permissible harmonics current A	Harmonics Order n	Max. permissible harmonics current per watt mA/W	Max. permissible harmonics current A
Odd harmonics		Odd Harmonics only		
3	2.30	3	3.4	2.30
5	1.14	5	1.9	1.14
7	0.77	7	1.0	0.77
9	0.40	9	0.5	0.40
11	0.33	11	0.35	0.33
13	0.21	13	0.30	0.21
$15 \leq n \leq 39$	$0.15 \times (15/n)$	$15 \leq n \leq 39$ (odd harmonics only)	$3.85/n$	$0.15 \times (15/n)$
Even harmonics				
2	1.08			
4	0.43			
6	0.30			
$8 \leq n \leq 40$	$0.23 \times 8/n$			

Limit for Class C equipment	
Harmonics Order n	Max. permissible harmonics current expressed as a percentage of the input current at the fundamental frequency A
2	2
3	$30 \times F$
5	10
7	7
9	5
$11 \leq n < \leq 39$ (odd harmonics only)	3

F is the circuit power factor

Note: Class A, B, C and D are classified according to item 7.4.2. of this report

7.4.2. TEST PROCEDURES

The EUT was placed on the top of a wooden table 0.8 meters above the ground and operated to produce the maximum harmonic. The classification of EUT is according to section 5 of EN 61000-3-2.

The EUT is classified as follows:

Class A:

Balanced three-phase equipment, Household appliances excluding equipment as Class D, Tools excluding portable tools, Dimmers for incandescent lamps, audio equipment, equipment not specified in one of the three other classes.

Class B:

Portable tools; Arc welding equipment which is not professional equipment.

Class C:

Lighting equipment

Class D:

Equipment having a specified power less than or equal to 600 W of the following types: Personal computers and personal computer monitors and television receivers.

The correspondent test program of test instrument to measure the current harmonics emanated from EUT is chosen. The measure time shall be not less than the time necessary for the EUT to be exercised.

7.4.3. TEST SETUP

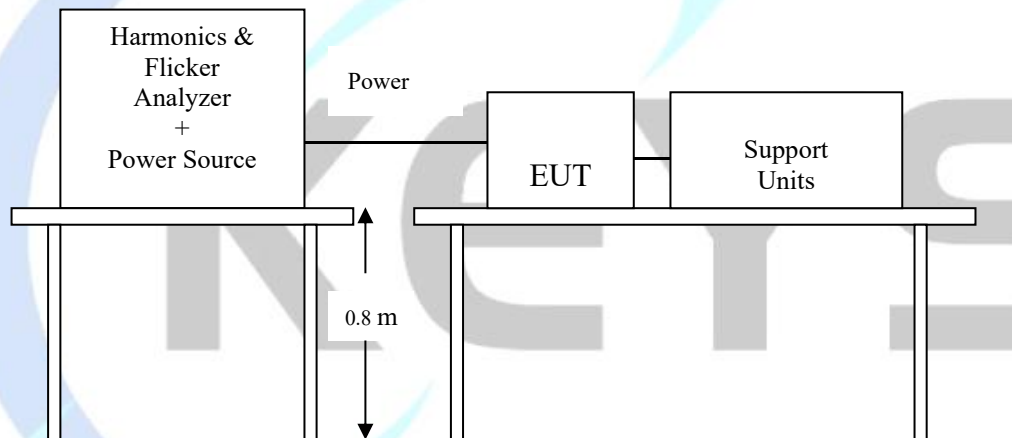

For the actual test configuration, please refer to the related item – Photographs of the Test Configuration.

7.4.4. TEST RESULT

Product	CEILING FAN WITH LIGHTS - WITH BLUETOOTH	Tested by	Brian
Model	001 038 300100 00 00	Limits	Class <input type="checkbox"/> A <input type="checkbox"/> B <input checked="" type="checkbox"/> C <input type="checkbox"/> D
Test Mode	Lighting	Observation Period (Tp)	2.5 mins
Environmental Conditions	24.3 °C, 54.1 % RH, 101.1 kPa	Test Result	Pass

8. Note: 1) Limits classified according to item 7.4.2 of this report.

Please refer to the following test data:

EUT: CEILING FAN WITH LIGHTS - WITH BLUETOOTH

M/N: 001 038 300100 00 00

Tested by: Brian



Report No: KEYS240801018002EM-02

Test category: Class-C per Ed. 4.0 (2014) (European limits)

Test Margin: 100

Test date: 2024/08/08

Start time: 09:00:03

End time: 10:18:16

Test duration (min): 5

Data file name: H-000211.cts_data

Comment: Lighting

Customer:

Test Result: Pass

Source qualification: Normal

Current & voltage waveforms

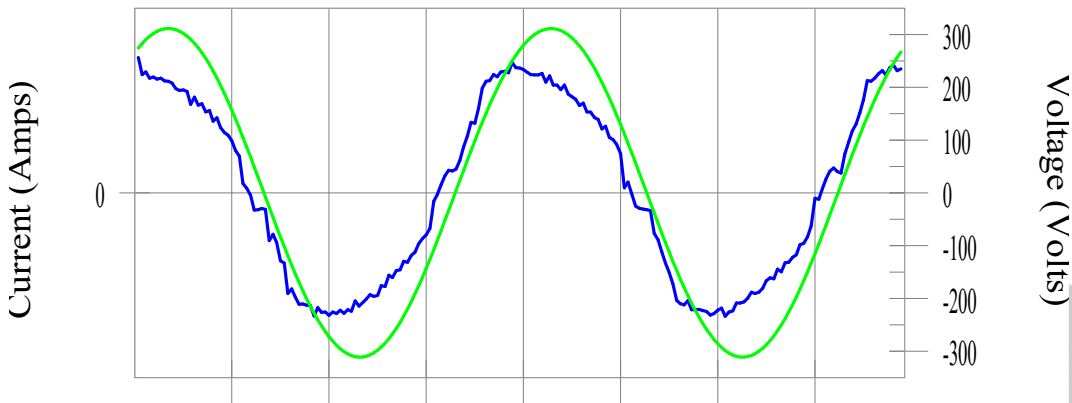

Harmonics and Class C limit line

European Limits

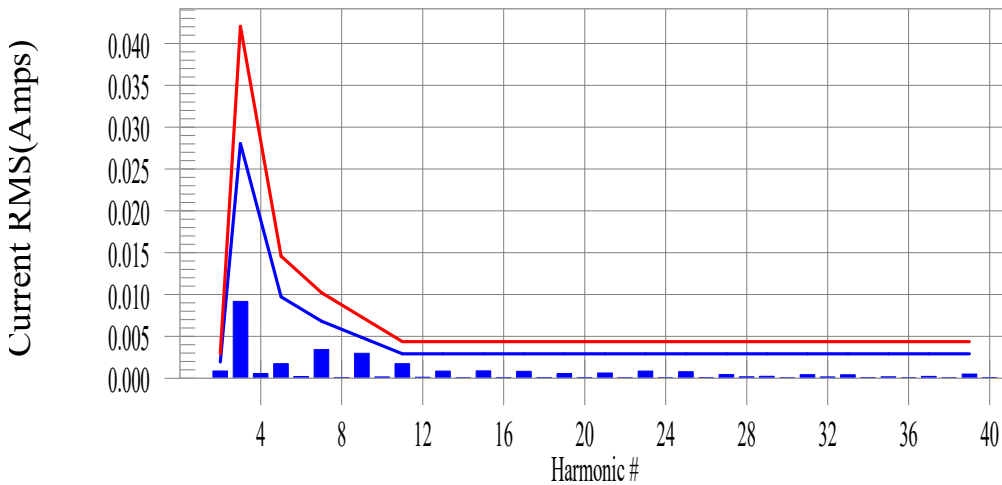

Test result: Pass Worst harmonics H5-62.1% of 150% limit, H5-91.5% of 100% limit.



Current Test Result Summary (Run time)

EUT: CEILING FAN WITH LIGHTS - WITH BLUETOOTH

M/N: 001 038 300100 00 00

Tested by: Brian

Test category: Class-C per Ed. 4.0 (2014) (European limits)

Test Margin: 100

Test date: 2024/08/08

Start time: 09:00:03

End time: 10:18:16

Test duration (min): 5

Data file name: H-000211.cts_data

Comment: Lighting

Customer:

Test Result: Pass

Source qualification: Normal

THC(A): 0.035

I-THD(%): 16.7

POHC(A): 0.000

POHC Limit(A): 0.020

Highest parameter values during test:

V_RMS (Volts): 230.63

Frequency(Hz): 50.00

I_Peak (Amps): 0.1632

I_RMS (Amps): 0.1587

I_Fund (Amps): 0.1561

Crest Factor: 0.1569

Power (Watts): 36.02

Power Factor: 0.978

Harm#	Harms(avg)	100%Limit	%of Limit	Harms(max)	150%Limit	%of Limit	Status
2	0.001	0.002	N/A	0.001	0.003	N/A	Pass
3	0.009	0.028	32.7	0.010	0.042	23.7	Pass
4	0.001	0.000	N/A	0.001	0.000	N/A	Pass
5	0.002	0.010	N/A	0.002	0.015	N/A	Pass
6	0.000	0.000	N/A	0.000	0.000	N/A	Pass
7	0.003	0.007	N/A	0.004	0.010	N/A	Pass
8	0.000	0.000	N/A	0.000	0.000	N/A	Pass
9	0.003	0.005	N/A	0.003	0.007	N/A	Pass
10	0.000	0.000	N/A	0.000	0.000	N/A	Pass
11	0.002	0.003	N/A	0.002	0.004	N/A	Pass
12	0.000	0.000	N/A	0.000	0.000	N/A	Pass
13	0.001	0.003	N/A	0.001	0.004	N/A	Pass
14	0.000	0.000	N/A	0.000	0.000	N/A	Pass
15	0.001	0.003	N/A	0.001	0.004	N/A	Pass
16	0.000	0.000	N/A	0.000	0.000	N/A	Pass



Report No: KEYS240801018002EM-02

17	0.001	0.003	N/A	0.001	0.004	N/A	Pass
18	0.000	0.000	N/A	0.000	0.000	N/A	Pass
19	0.001	0.003	N/A	0.001	0.004	N/A	Pass
20	0.000	0.000	N/A	0.000	0.000	N/A	Pass
21	0.001	0.003	N/A	0.001	0.004	N/A	Pass
22	0.000	0.000	N/A	0.000	0.000	N/A	Pass
23	0.001	0.003	N/A	0.001	0.004	N/A	Pass
24	0.000	0.000	N/A	0.000	0.000	N/A	Pass
25	0.001	0.003	N/A	0.001	0.004	N/A	Pass
26	0.000	0.000	N/A	0.000	0.000	N/A	Pass
27	0.000	0.003	N/A	0.000	0.004	N/A	Pass
28	0.000	0.000	N/A	0.000	0.000	N/A	Pass
29	0.000	0.003	N/A	0.000	0.004	N/A	Pass
30	0.000	0.000	N/A	0.000	0.000	N/A	Pass
31	0.000	0.003	N/A	0.000	0.004	N/A	Pass
32	0.000	0.000	N/A	0.000	0.000	N/A	Pass
33	0.000	0.003	N/A	0.000	0.004	N/A	Pass
34	0.000	0.000	N/A	0.000	0.000	N/A	Pass
35	0.000	0.003	N/A	0.000	0.004	N/A	Pass
36	0.000	0.000	N/A	0.000	0.000	N/A	Pass
37	0.000	0.003	N/A	0.000	0.004	N/A	Pass
38	0.000	0.000	N/A	0.000	0.000	N/A	Pass
39	0.000	0.003	N/A	0.001	0.004	N/A	Pass
40	0.000	0.000	N/A	0.000	0.000	N/A	Pass

Note: Dynamic limits were applied for this test. The highest harmonics values in the above table may not occur at the same window as the maximum harmonics/limit ratio.



Voltage Source Verification Data (Run time)

EUT: CEILING FAN WITH LIGHTS - WITH BLUETOOTH M/N: 001 038 300100 00 00

Tested by: Brian

Test category: Class-C per Ed. 4.0 (2014) (European limits) Test Margin: 100

Test date: 2024/08/08 Start time: 09:00:03 End time: 10:18:16

Test duration (min): 5 Data file name: H-000211.cts_data

Comment: Lighting

Customer:

Test Result: Pass Source qualification: Normal

Highest parameter values during test:

V_RMS (Volts):	230.63	Frequency(Hz):	50.00
I_Peak (Amps):	0.1632	I_RMS (Amps):	0.1587
I_Fund (Amps):	0.1561	Crest Factor:	0.1569
Power (Watts):	36.02	Power Factor:	0.978

Harm#	Harmonics V-rms	Limit V-rms	% of Limit	Status
2	0.060	0.440	13.70	OK
3	0.320	1.981	16.13	OK
4	0.037	0.440	8.38	OK
5	0.027	0.881	3.10	OK
6	0.019	0.440	4.40	OK
7	0.025	0.660	3.86	OK
8	0.010	0.440	2.38	OK
9	0.011	0.440	2.52	OK
10	0.012	0.440	2.62	OK
11	0.019	0.220	8.55	OK
12	0.008	0.220	3.69	OK
13	0.011	0.220	4.87	OK
14	0.006	0.220	2.64	OK
15	0.012	0.220	5.34	OK
16	0.005	0.220	2.18	OK
17	0.006	0.220	2.63	OK
18	0.005	0.220	2.08	OK
19	0.011	0.220	4.82	OK



Report No: KEYS240801018002EM-02

20	0.011	0.220	5.06	OK
21	0.007	0.220	3.30	OK
22	0.003	0.220	1.50	OK
23	0.006	0.220	2.71	OK
24	0.003	0.220	1.35	OK
25	0.005	0.220	2.19	OK
26	0.003	0.220	1.40	OK
27	0.006	0.220	2.92	OK
28	0.004	0.220	1.64	OK
29	0.004	0.220	1.65	OK
30	0.002	0.220	1.01	OK
31	0.005	0.220	2.34	OK
32	0.003	0.220	1.46	OK
33	0.007	0.220	3.25	OK
34	0.003	0.220	1.41	OK
35	0.005	0.220	2.48	OK
36	0.002	0.220	1.06	OK
37	0.003	0.220	1.49	OK
38	0.003	0.220	1.28	OK
39	0.006	0.220	2.68	OK
40	0.010	0.220	4.33	OK

7.5. VOLTAGE FLUCTUATION AND FLICKS MEASUREMENT

7.5.1. LIMITS OF VOLTAGE FLUCTUATION AND FLICKS MEASUREMENT

TEST ITEM	LIMIT	REMARK
P_{st}	1.0	P_{st} means short-term flicker indicator.
P_{lt}	0.65	P_{lt} means long-term flicker indicator.
T_{dt} (ms)	500	T_{dt} means maximum time that dt exceeds 3 %.
d_{max} (%)	4/6/7 %	d_{max} means maximum relative voltage change.
dc (%)	3.3 %	dc means relative steady-state voltage change

7.5.2. TEST PROCEDURE

The EUT was placed on the top of a wooden table 0.8 meters above the ground and operated to produce the most unfavorable sequence of voltage changes under lighting operating conditions. During the flick measurement, the measure time shall include that part of whole operation cycle in which the EUT produce the most unfavorable sequence of voltage changes. The observation period for short-term flicker indicator is 10 minutes and the observation period for long-term flicker indicator is 2 hours.

7.5.3. TEST SETUP

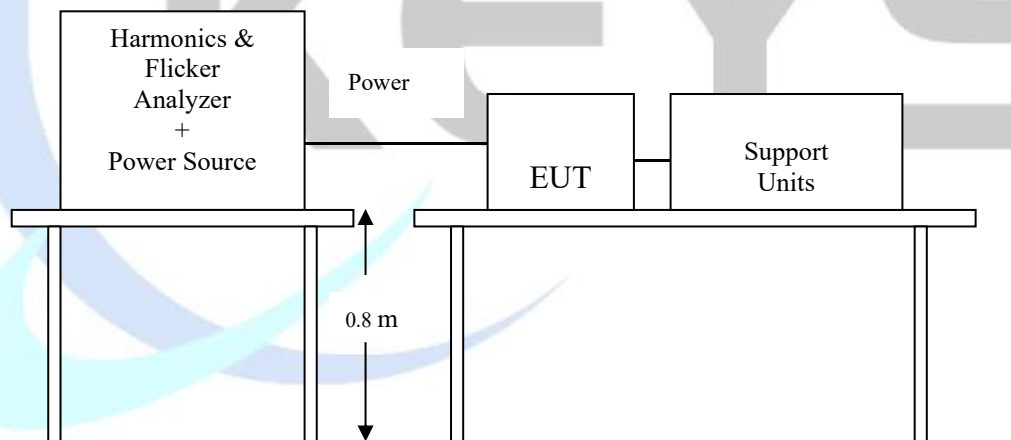

For the actual test configuration, please refer to the related item – Photographs of the Test Configuration.

7.5.4. TEST RESULT

Product	CEILING FAN WITH LIGHTS - WITH BLUETOOTH	Tested by	Brian
Model	001 038 300100 00 00	Observation Period (Tp)	10 mins
Test Mode	Lighting	Test Result	Pass
Environmental Conditions	24.3 °C, 54.1 % RH, 101.1 kPa		



Please refer to the following test data:

EUT: CEILING FAN WITH LIGHTS - WITH BLUETOOTH **M/N: 001 038 300100 00 00**

Tested by: Brian

Test category: All parameters (European limits) **Test Margin: 100**

Test date: 2024/08/08 **Start time: 11:21:01** **End time: 12:30:00**

Test duration (min): 10 **Data file name: F-000036.cts_data**

Comment: Lighting

Customer:

Test Result: Pass **Status: Test Completed**

Pst_i and limit line **European Limits**

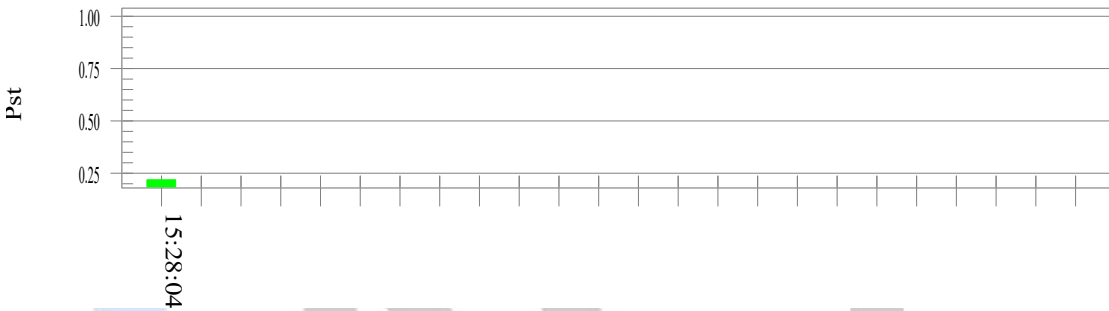

Plt and limit line



Parameter values recorded during the test:

Vrms at the end of test (Volt):	230.05			
Highest dt (%):	0.00	Test limit (%):	N/A	N/A
T-max (mS):	0	Test limit (mS):	500.1	Pass
Highest dc (%):	0.00	Test limit (%):	3.32	Pass
Highest dmax (%):	0.04	Test limit (%):	4.06	Pass
Highest Pst (10 min. period):	0.218	Test limit:	1.009	Pass
Highest Plt (2 hr. period):	0.093	Test limit:	0.658	Pass

8. IMMUNITY TEST

8.1. GENERAL DESCRIPTION

Product Standard	EN 61547	
	Test Type	Minimum Requirement
Basic Standard, Specification, and Performance Criterion required	EN 61000-4-2	Electrostatic Discharge – ESD: 8 kV air discharge, 4 kV Contact discharge, Performance Criterion B
	EN 61000-4-3	Radio-Frequency Electromagnetic Field Susceptibility Test – RS: 80 ~1000 MHz, 3 V/m, 80 % AM(1 kHz), Performance Criterion A
	EN 61000-4-4	Electrical Fast Transient/Burst - EFT, Power line: 1 kV, Signal line: 0.5 kV, Performance Criterion B
	EN 61000-4-5	Surge Immunity Test: 1.2/50 μ s Open Circuit Voltage, 8 /20 μ s Short Circuit Current, Power Port ~ Line to line: 0.5 kV, Line to ground: 1 kV (to self-ballasted lamps and semi-luminaries; luminaires and independent auxiliaries which are less than or equal to 25 W) Power Port ~ Line to line: 1 kV, Line to ground: 2 kV (to luminaires and independent auxiliaries which are more than 25 W) Signal Port : 0.5 kV Performance Criterion B
	EN 61000-4-6	Conducted Radio Frequency Disturbances Test –CS: 0.15 ~ 80 MHz, 3 Vrms, 80 % AM, 1 kHz, Performance Criterion A
	EN 61000-4-8	Power frequency magnetic field immunity test 50 Hz, 3 A/m Performance Criterion A
	EN 61000-4-11	Voltage Dips and Interruptions: i) 30 % reduction for 10 period, Performance Criterion C ii) 100 % reduction for 0.5 period Performance Criterion B

8.2. GENERAL PERFORMANCE CRITERIA DESCRIPTION

<p>Criteria A:</p>	<p>During the test no change of the luminous intensity shall be observed and the regulating control, if any, shall operate during the test as intended.</p>
<p>Criteria B:</p>	<p>During the test the luminous intensity may change to any value. After the test the luminous intensity shall be restored to its initial value within 1 min.</p> <p>Regulating controls need not function during the test, but after the test the mode of the control shall be the same as before the test provided that during the test no mode changing commands were given.</p>
<p>Criteria C:</p>	<p>During and after the test any change of the luminous intensity is allowed and the lamp(s) may be extinguished. After the test, within 30 min, all functions shall return to normal. if necessary by temporary interruption of the mains supply and/or operating the regulating control.</p> <p>Additional requirement for lighting equipment incorporating a starting device:</p> <p>After the test the lighting equipment is switched off. After half an hour it is switched on again. The lighting equipment shall start and operate as intended.</p>

8.3. ELECTROSTATIC DISCHARGE (ESD)

8.3.1. TEST SPECIFICATION

Basic Standard:	EN 61000-4-2
Discharge Impedance:	330 Ω
Charging Capacity:	150 pF
Discharge Voltage:	Air Discharge: 8 kV (Direct) Contact Discharge: 4 kV (Direct/Indirect)
Polarity:	Positive & Negative
Number of Discharge:	10 times at each test point
Discharge Mode:	1 time/s
Performance Criterion:	B

8.3.2. TEST PROCEDURE

The discharges shall be applied in two ways:

a) Contact discharges to the conductive surfaces and coupling planes:
Twenty dischargers (10 with positive and 10 with negative polarity) shall be applied on each accessible metallic part of the enclosure, terminals are excluded. In case of a non-conductive enclosure, dischargers shall be applied on the horizontal or vertical coupling planes. Test shall be performed at a maximum repetition rate of one discharge per second.

b) Air discharges at slots and apertures and insulating surfaces:
On those parts of the EUT where it is not possible to perform contact discharge testing, the equipment should be investigated to identify user accessible points where breakdown may occur. Such points are tested using the air discharge method. This investigation should be restricted to those area normally handled by the user. A minimum of 10 single air discharges shall be applied to the selected test point for each such area.

The basic test procedure was in accordance with IEC 61000-4-2:

- The EUT was located 0.1 m minimum from all side of the HCP (dimensions 1.6 m x 0.8 m).
- The support units were located another table 30 cm away from the EUT, but direct support unit was/were located at same location as EUT on the HCP and keep at a distance of 10cm with EUT.
- The time interval between two successive single discharges was at least 1 second.
- Contact discharges were applied to the non-insulating coating, with the pointed tip of the generator penetrating the coating and contacting the conducting substrate.

e) Air discharges were applied with the round discharge tip of the discharge electrode approaching the EUT as fast as possible (without causing mechanical damage) to touch the EUT. After each discharge, the ESD generator was removed from the EUT and re-triggered for a new single discharge. The test was repeated until all discharges were complete.

f) At least ten single discharges (in the most sensitive polarity) were applied at the front edge of each HCP opposite the center point of each unit of the EUT and 0.1 meters from the front of the EUT. The long axis of the discharge electrode was in the plane of the HCP and perpendicular to its front edge during the discharge.

g) At least ten single discharges (in the most sensitive polarity) were applied to the center of one vertical edge of the Vertical Coupling Plane (VCP) in sufficiently different positions that the four faces of the EUT were completely illuminated. The VCP (dimensions 0.5 m x 0.5 m) was placed vertically to and 0.1 meters from the EUT.

8.3.3. TEST SETUP

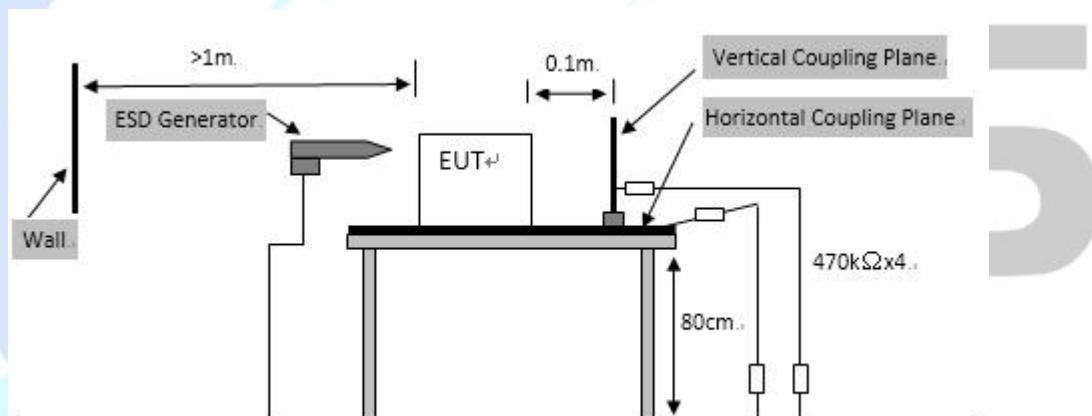

For the actual test configuration, please refer to the related item – Photographs of the Test Configuration.

Note:

1) TABLE-TOP EQUIPMENT

The configuration consisted of a wooden table 0.8 meters high standing on the ground reference plane (GRP). The GRP consisted of a sheet of aluminum at least 0.25 mm thick, and 2.5 meters square connected to the protective grounding system. A horizontal coupling plane (HCP) (1.6 m x 0.8 m) was placed on the table and attached to the GRP by means of a cable with 940k total impedance. The equipment under test, was installed in a representative system as described in section 7 of EN 61000-4-2, and its cables were placed on the HCP and isolated by an insulating support of 0.5 mm thickness. A distance of 1-meter minimum was provided between the EUT and the walls of the laboratory and any other metallic structure.

2) FLOOR-STANDING EQUIPMENT



Report No: KEYS240801018002EM-02

The equipment under test was installed in a representative system as described in section 7 of IEC 61000-4-2, and its cables were isolated from the ground reference plane by an insulating support of 0.1 meter thickness. The GRP consisted of a sheet of aluminum that is at least 0.25 mm thick, and 2.5 meters square connected to the protective grounding system and extended at least 0.5 meters from the EUT on all sides.

8.3.4. TEST RESULT

Product	CEILING FAN WITH LIGHTS - WITH BLUETOOTH	Environmental Conditions	24.3 °C, 52 % RH, 101.2 kPa
Model	001 038 300100 00 00	Tested By	Brian
Test mode	Lighting	Test Result	Pass

Air Discharge					
Test Points	Test Levels	Results			
	8 kV	Pass	Fail	Observation	Performance Criterion
LED	<input checked="" type="checkbox"/>	<input checked="" type="checkbox"/>	<input type="checkbox"/>	Note <input type="checkbox"/> 1 <input checked="" type="checkbox"/> 2 <input type="checkbox"/> 3	B
Gap	<input checked="" type="checkbox"/>	<input checked="" type="checkbox"/>	<input type="checkbox"/>	Note <input type="checkbox"/> 1 <input checked="" type="checkbox"/> 2 <input type="checkbox"/> 3	B

Contact Discharge					
Test Points	Test Levels	Results			
	4 kV	Pass	Fail	Observation	Performance Criterion
HCP	<input checked="" type="checkbox"/>	<input checked="" type="checkbox"/>	<input type="checkbox"/>	Note <input type="checkbox"/> 1 <input checked="" type="checkbox"/> 2 <input type="checkbox"/> 3	B
VCP	<input checked="" type="checkbox"/>	<input checked="" type="checkbox"/>	<input type="checkbox"/>	Note <input type="checkbox"/> 1 <input checked="" type="checkbox"/> 2 <input type="checkbox"/> 3	B
Screw	<input checked="" type="checkbox"/>	<input checked="" type="checkbox"/>	<input type="checkbox"/>	Note <input type="checkbox"/> 1 <input checked="" type="checkbox"/> 2 <input type="checkbox"/> 3	B

- Note: 1) There was no change compared with initial operation during the test.
 2) During the test the luminous intensity change, and after the test the luminous intensity can be restored to its initial value within 1 min.
 3) During the test, the luminous intensity change and after the test the luminous intensity can return to normal within 30 min.

8.4. RADIATED, RADIO-FREQUENCY, ELECTROMAGNETIC FIELD (RS)

8.4.1. TEST SPECIFICATION

Basic Standard:	EN 61000-4-3
Frequency Range:	80 MHz ~ 1000 MHz
Field Strength:	3 V/m
Modulation:	1 kHz Sine Wave, 80 %, AM Modulation
Frequency Step:	1 % of preceding frequency value
Polarity of Antenna:	Horizontal and Vertical
Test Distance:	3 m
Antenna Height:	1.5 m
Performance Criterion:	A

8.4.2. TEST PROCEDURE

The test procedure was in accordance with EN 61000-4-3

- The testing was performed in a fully anechoic chamber. The transmit antenna was located at a distance of 3 meters from the EUT.
- The frequency range is swept from 80 MHz to 1000 MHz, with the signal 80% amplitude modulated with a 1 kHz sine-wave. The rate of sweep did not exceed 1.5×10^{-3} decade/s, where the frequency range is swept incrementally, the step size was 1 % of preceding frequency value.
- The dwell time at each frequency shall be not less than the time necessary for the EUT to be able to respond.
- The test was performed with the EUT exposed to both vertically and horizontally polarized fields on each of the four sides.

8.4.3. TEST SETUP

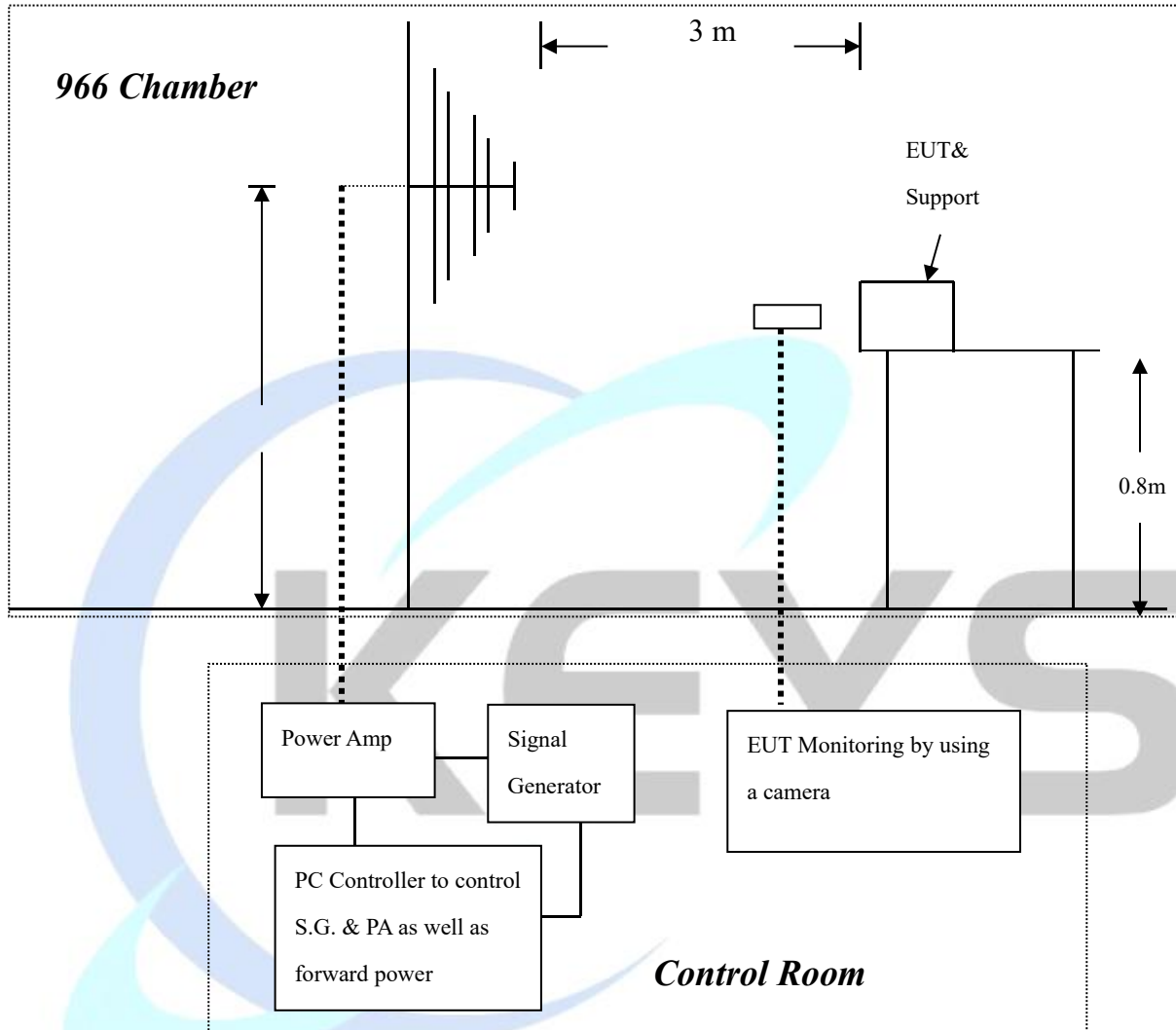

For the actual test configuration, please refer to the related item – Photographs of the Test Configuration.
 Note:

TABLETOP EQUIPMENT

The EUT installed in a representative system as described in section 7 of EN 61000-4-3 was placed on a non-conductive table 0.8 meters in height. The system under test was connected to the power and signal wire according to relevant installation instructions.

FLOOR STANDING EQUIPMENT

The EUT installed in a representative system as described in section 7 of IEC 61000-4-3 was placed on a non-conductive wood support 0.1 meters in height. The system under test was connected to the power and signal wire according to relevant installation instructions.

8.4.4. TEST RESULT

Product	CEILING FAN WITH LIGHTS - WITH BLUETOOTH	Environmental Conditions	24.5°C, 54 % RH
Model	001 038 300100 00 00	Tested By	Brian
Test mode	Lighting	Test Result	Pass

Frequency (MHz)	Polarity	Position	Field Strength (V/m)	Observation	Performance Criterion
80 ~ 1000	V&H	Front	3	Note <input checked="" type="checkbox"/> 1 <input type="checkbox"/> 2 <input type="checkbox"/> 3	A
80 ~ 1000	V&H	Rear	3	Note <input checked="" type="checkbox"/> 1 <input type="checkbox"/> 2 <input type="checkbox"/> 3	A
80 ~ 1000	V&H	Left	3	Note <input checked="" type="checkbox"/> 1 <input type="checkbox"/> 2 <input type="checkbox"/> 3	A
80 ~ 1000	V&H	Right	3	Note <input checked="" type="checkbox"/> 1 <input type="checkbox"/> 2 <input type="checkbox"/> 3	A

- Note: 1) There was no change compared with initial operation during the test.
 2) During the test the luminous intensity change ,and after the test the luminous intensity can be restored to its initial value within 1 min.
 3) During the test, the luminous intensity change and after the test the luminous intensity can return to normal within 30 min.

8.5. ELECTRICAL FAST TRANSIENT (EFT)

8.5.1. TEST SPECIFICATION

Basic Standard:	EN 61000-4-4
Test Voltage:	Power Line: 1 kV Signal/Control Line: 0.5 kV
Polarity:	Positive & Negative
Impulse Frequency:	5 kHz
Impulse Wave-shape:	5/50 ns
Burst Duration:	15 ms
Burst Period:	300 ms
Test Duration:	2 mins
Performance Criterion:	B

8.5.2. TEST PROCEDURE

EUT is placed on a 0.1 m tall wooden table.

EUT operate at normal mode, the transient/burst was 5/50 ns in accordance with EN 61000-4-4, both positive and negative polarity burst waveform were applied.

The duration time of each test line was 2 minutes.

8.5.3. TEST SETUP

The EUT installed in a representative system as described in section 7 of EN 61000-4-4.

For the actual test configuration, please refer to the related item – photographs of the test configuration.

8.5.4. TEST RESULT

Product	CEILING FAN WITH LIGHTS - WITH BLUETOOTH	Environmental Conditions	24.3 °C, 54.% RH, 101.2kPa
Model	001 038 300100 00 00	Tested By	Brian
Test mode	Lighting	Test Result	Pass

Test Point	Polarity	Test Level (kV)	Observation	Performance Criterion
L	+/-	1	Note <input type="checkbox"/> 1 <input checked="" type="checkbox"/> 2 <input type="checkbox"/> 3	B
N	+/-	1	Note <input type="checkbox"/> 1 <input checked="" type="checkbox"/> 2 <input type="checkbox"/> 3	B
L – N	+/-	1	Note <input type="checkbox"/> 1 <input checked="" type="checkbox"/> 2 <input type="checkbox"/> 3	B
PE	+/-	1	Note <input type="checkbox"/> 1 <input checked="" type="checkbox"/> 2 <input type="checkbox"/> 3	B
L – PE	+/-	1	Note <input type="checkbox"/> 1 <input checked="" type="checkbox"/> 2 <input type="checkbox"/> 3	B
N – PE	+/-	1	Note <input type="checkbox"/> 1 <input checked="" type="checkbox"/> 2 <input type="checkbox"/> 3	B
L – N – PE	+/-	1	Note <input type="checkbox"/> 1 <input checked="" type="checkbox"/> 2 <input type="checkbox"/> 3	B
Signal/Control cable	+/-	0.5	Note <input type="checkbox"/> 1 <input checked="" type="checkbox"/> 2 <input type="checkbox"/> 3	B

Note: 1) There was no change compared with initial operation during the test.

2) During the test the luminous intensity change ,and after the test the luminous intensity can be restored to its initial value within 1 min.

3) During the test, the luminous intensity change and after the test the luminous intensity can return to normal within 30 min.

8.6. SURGE IMMUNITY TEST

8.6.1. TEST SPECIFICATION

Basic Standard:	EN 61000-4-5
Wave-Shape:	Combination Wave 1.2/50 μ s Open Circuit Voltage 8/20 μ s Short Circuit Current Power Port ~ Line to line: 0.5 kV, Line to ground: 1 kV (to self-ballasted lamps and semi-luminaires; luminaires and independent auxiliaries which are less than 25 W)
Test Voltage:	Power Port ~ Line to line: 1 kV, Line to ground: 2 kV (to luminaires and independent auxiliaries which are more than 25 W)
Surge Input/Output:	Power Line: L-N / L-PE / N-PE
Generator Source Impedance:	2 Ω between networks 12 Ω between network and ground
Polarity:	Positive/Negative
Phase Angle:	90°(positive polarity pulses) / 270°(negative polarity pulses)
Pulse Repetition Rate:	1 time / min.
Number of Tests:	5 positive polarity pulses at the 90° phase angle, and 5 negative polarity pulses at 270° phase angle
Performance Criterion:	A

8.6.2. TEST PROCEDURE

EUT is placed on a 0.1 m (table type equipment) / 0.8 m (floor type equipment) tall wooden table.

EUT operate at normal mode, two types of combination wave generator (1.2/50 μ s open-circuit voltage and 8/20 μ s short-circuit current) are applied to the EUT power supply terminals via the capacitive coupling network.

The power cord between the EUT and the coupling/decoupling network shall not exceed 2 m in length.

8.6.3. TEST SETUP

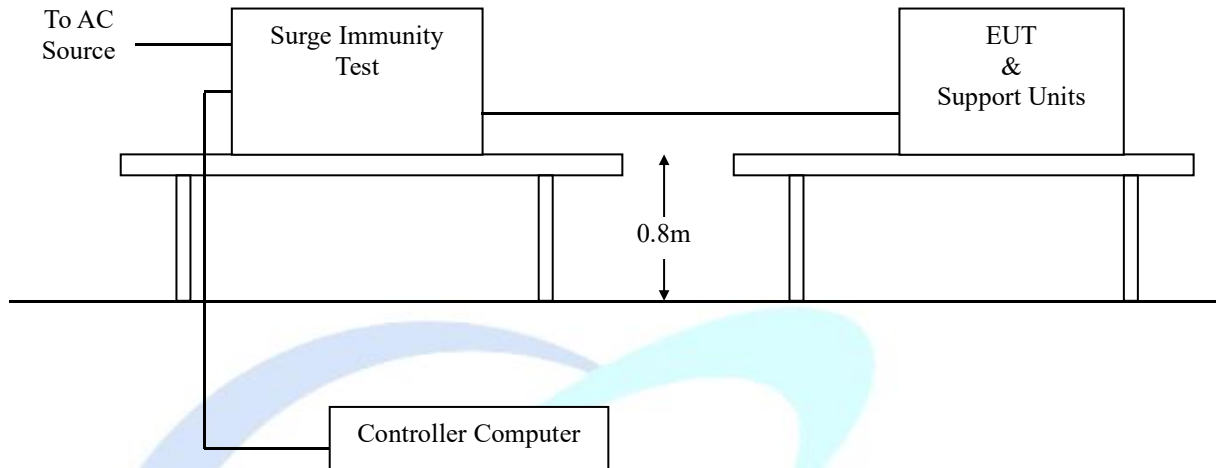

For the actual test configuration, please refer to the related item – Photographs of the Test Configuration.

8.6.4. TEST RESULT

Product	CEILING FAN WITH LIGHTS - WITH BLUETOOTH	Environmental Conditions	24.6°C, 52 % RH, 100.8 kPa
Model	001 038 300100 00 00	Tested By	Brian
Test mode	Lighting	Test Result	Pass

Test Point	Polarity	Test Level (kV)	Observation	Performance Criterion
L - N	+/-	1	Note <input type="checkbox"/> 1 <input checked="" type="checkbox"/> 2 <input type="checkbox"/> 3	A
L - PE	+/-	2	Note <input type="checkbox"/> 1 <input checked="" type="checkbox"/> 2 <input type="checkbox"/> 3	A
N - PE	+/-	2	Note <input type="checkbox"/> 1 <input checked="" type="checkbox"/> 2 <input type="checkbox"/> 3	A

- Note: 1) There was no change compared with initial operation during the test.
 2) During the test the luminous intensity change ,and after the test the luminous intensity can be restored to its initial value within 1 min.
 3) During the test, the luminous intensity change and after the test the luminous intensity can return to normal within 30 min.

8.7. CONDUCTED RADIO FREQUENCY DISTURBANCES (CS)

8.7.1. TEST SPECIFICATION

Basic Standard:	EN 61000-4-6
Frequency Range:	0.15 MHz ~80 MHz
Field Strength:	3 V
Modulation:	1 kHz Sine Wave, 80 %, AM Modulation
Frequency Step:	1 % of preceding frequency value
Coupled cable:	Power Mains, Shielded
Coupling device:	CDN-M3/2 (3 wires/2 wires)
Performance Criterion:	A

8.7.2. TEST PROCEDURE

The EUT shall be tested within its intended operating and climatic conditions.

The test shall be performed with the test generator connected to each of the coupling and decoupling devices in turn, while the other non-excited RF input ports of the coupling devices are terminated by a 50 Ω load resistor.

The frequency range was swept from 150 kHz to 80 MHz, using the signal level established during the setting process and with a disturbance signal of 80 % amplitude. The signal was modulated with a 1 kHz sine wave, pausing to adjust the RF signal level or the switch coupling devices as necessary. The sweep rate was 1.5×10^{-3} decades/s. Where the frequency range is swept incrementally, the step size was 1 % of preceding frequency value the dwell time of the amplitude modulated carrier at each frequency was 0.5 s.

8.7.3. TEST SETUP

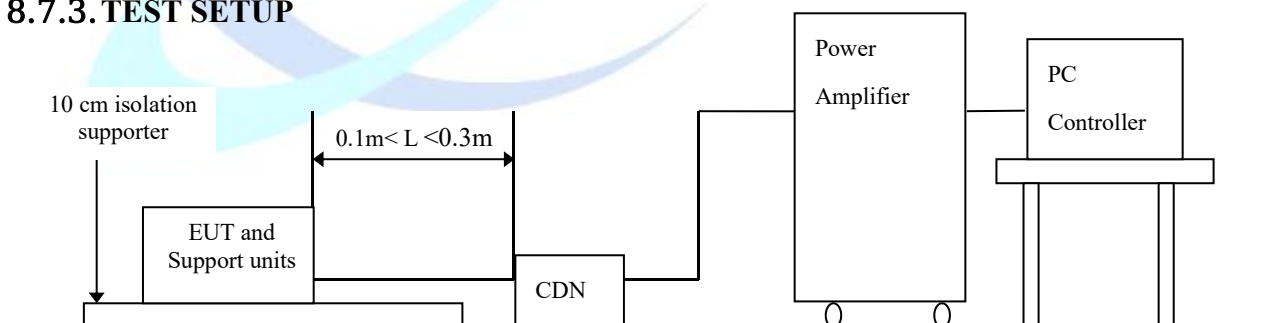

For the actual test configuration, please refer to the related item – Photographs of the Test Configuration

Note: 1) The EUT is setup 0.1 m above Ground Reference Plane

2) All relevant cables shall be provided with the appropriate coupling and decoupling devices at a distance between 0.1 meters and 0.3 meters from the projected geometry of the EUT on the ground reference plane.

8.7.4. TEST RESULT

Product	CEILING FAN WITH LIGHTS - WITH BLUETOOTH	Environmental Conditions	23.9°C, 50 % RH, 100.6 kPa
Model	001 038 300100 00 00	Tested By	Brian
Test mode	Lighting	Test Result	Pass

Frequency (MHz)	Field Strength (Vrms)	Injected Position	Injection Method	Observation	Performance Criterion
0.15 ~ 80	3	AC Mains	CDN-M2/M3	Note <input checked="" type="checkbox"/> 1 <input type="checkbox"/> 2 <input type="checkbox"/> 3	A

- Note: 1) There was no change compared with initial operation during the test.
 2) During the test the luminous intensity change ,and after the test the luminous intensity can be restored to its initial value within 1 min.
 3) During the test, the luminous intensity change and after the test the luminous intensity can return to normal within 30 min.



8.8. POWER FREQUENCY MAGNETIC FIELD

8.8.1. TEST SPECIFICATION

Basic Standard:	EN 61000-4-8
Frequency Range:	50 Hz
Field Strength:	1A/m
Observation Time:	5 minutes
Inductance Coil:	Rectangular type, 1 m x 1 m
Performance Criterion:	A

8.8.2. TEST PROCEDURE

The equipment is configured and connected to satisfy its functional requirements. It shall be placed on the GRP with the interposition of a 0.1 m-thick insulating support.

The equipment cabinets shall be connected to the safety earth directly on the GRP via the earth terminal of the EUT.

The power supply, input and output circuits shall be connected to the sources of power supply, control and signal.

The cables supplied or recommended by the equipment manufacturer shall be used. 1 meter of all cables used shall be exposed to the magnetic field.

8.8.3. TEST SETUP

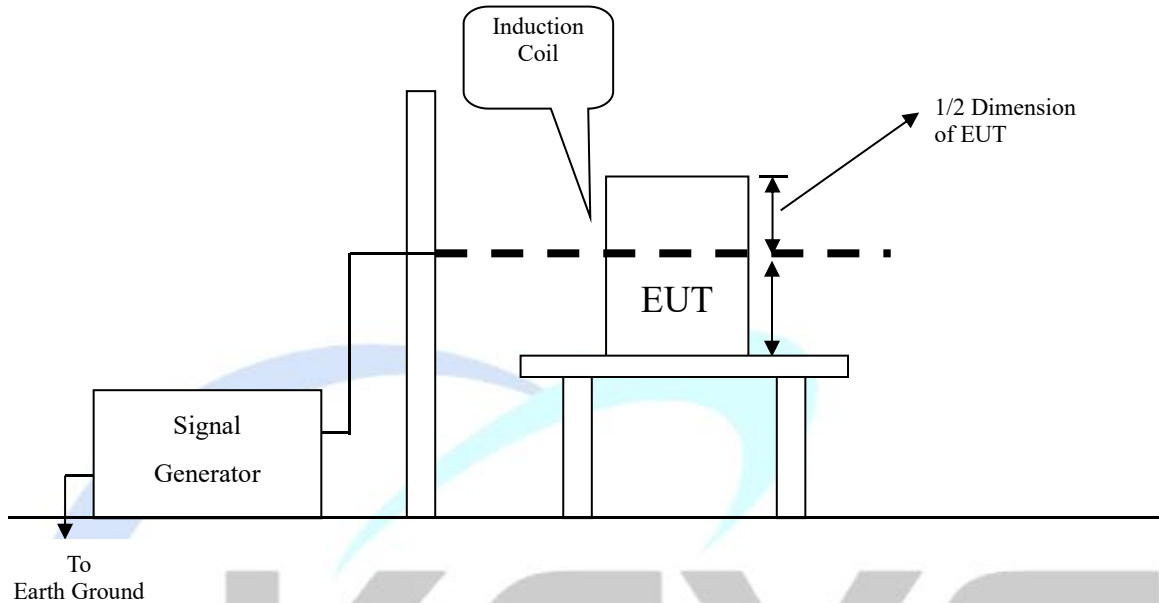

For the actual test configuration, please refer to the related item – Photographs of the Test Configuration
Note:

TABLETOP EQUIPMENT

The equipment shall be subjected to the test magnetic field by using the induction coil of standard dimension (1 m x 1 m). The induction coil shall then be rotated by 90 degrees in order to expose the EUT to the test field with different orientations.

FLOOR-STANDING EQUIPMENT

The equipment shall be subjected to the test magnetic field by using induction coils of suitable dimensions. The test shall be repeated by moving and shifting the induction coils, in order to test the whole volume of the EUT for each orthogonal direction. The test shall be repeated with the coil shifted to different positions along the side of the EUT, in steps corresponding to 50 % of the shortest side of the coil. The induction coil shall then be rotated by 90 degrees in order to expose the EUT to the test field with different orientations.

8.8.4. TEST RESULT

N/A

8.9. VOLTAGE DIP & VOLTAGE INTERRUPTIONS

8.9.1. TEST SPECIFICATION

Basic Standard:	EN 61000-4-11
Test Duration Time:	3 test events in sequence
Interval Between Event:	10 seconds
Phase Angle:	0°
Test Cycle:	3 times
Performance Criterion:	0% U_T / 0.5 P, Criterion: B 70% U_T / 25 P, Criterion: C 0% U_T / 250 P, Criterion: C

8.9.2. TEST PROCEDURE

The EUT and support units were located on a wooden table, 0.8 m away from ground floor.

Setting the parameter of tests and then perform the test software of test simulator.

Changes to the voltage level shall occur at 0 degree crossing point in the a.c. voltage waveform.

Record the test result in test record form.

8.9.3. TEST SETUP

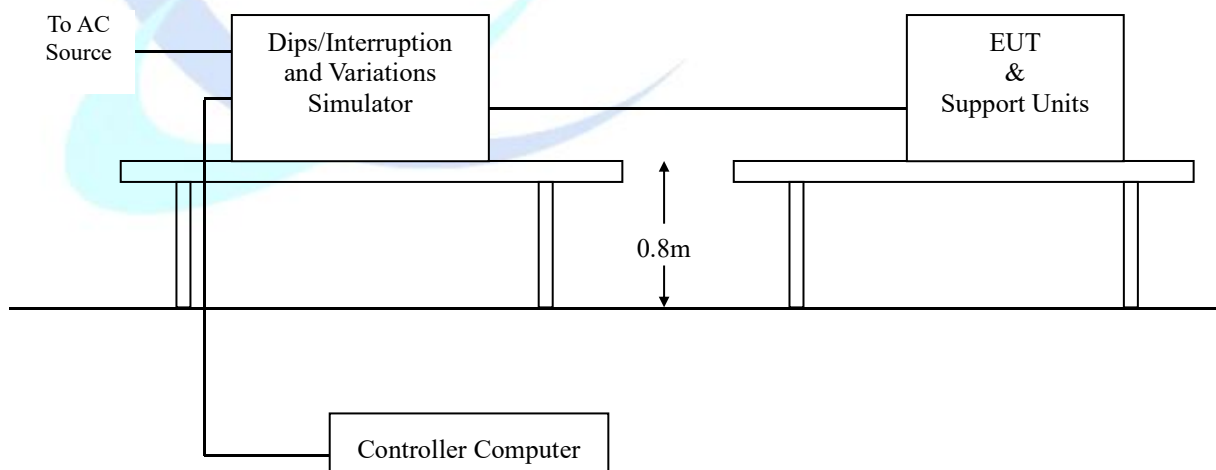

For the actual test configuration, please refer to the related item – Photographs of the Test Configuration.

8.9.4. TEST RESULT

Product	CEILING FAN WITH LIGHTS - WITH BLUETOOTH	Environmental Conditions	24.3 °C, 54 % RH, 101.2 kPa
Model	001 038 300100 00 00	Tested By	Brian
Test mode	Lighting	Test Result	Pass

Test Power: 230 VAC, 50 Hz			
Voltage (% Reduction)	Duration (Period)	Observation	Performance Criterion
0	0.5	Note <input type="checkbox"/> 1 <input checked="" type="checkbox"/> 2 <input type="checkbox"/> 3	B
70	25	Note <input type="checkbox"/> 1 <input type="checkbox"/> 2 <input checked="" type="checkbox"/> 3	C
0	250	Note <input type="checkbox"/> 1 <input type="checkbox"/> 2 <input checked="" type="checkbox"/> 3	C

- Note: 1) There was no change compared with initial operation during the test.
 2) During the test the luminous intensity change ,and after the test the luminous intensity can be restored to its initial value within 1 min.
 3) During the test, the luminous intensity change, and after the test the luminous intensity can return to normal within 30 min.

9. PHOTOGRAPHS OF THE TEST CONFIGURATION CONDUCTED EMISSION TEST

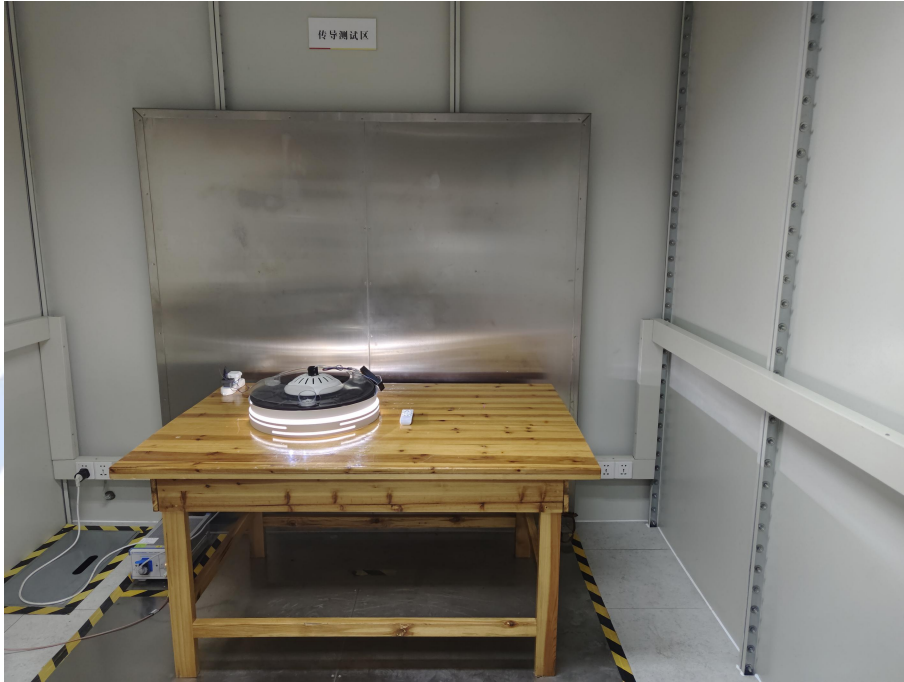

RADIATED EMISSION TEST

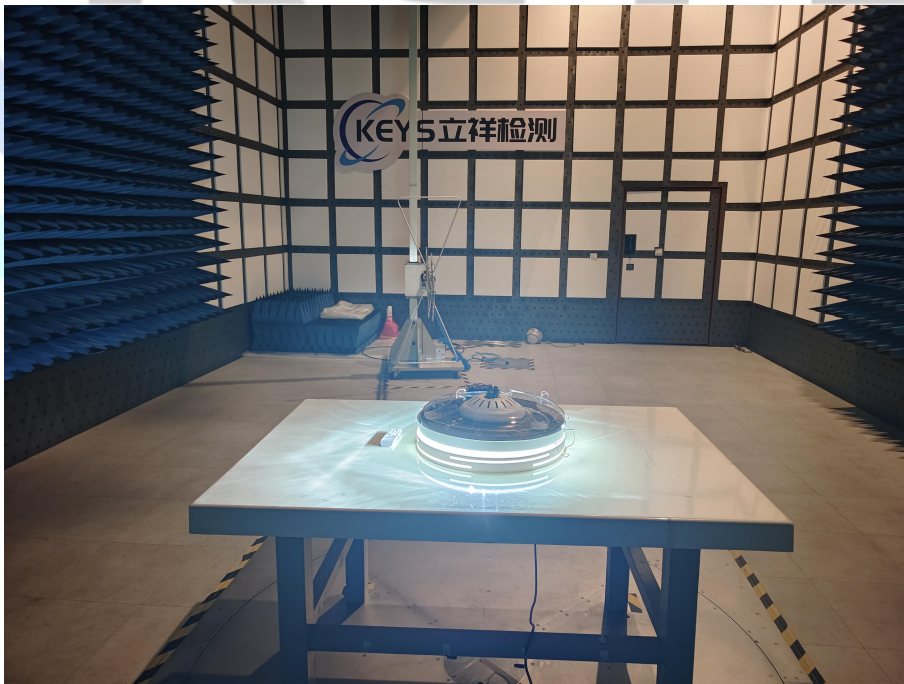

ESD TEST

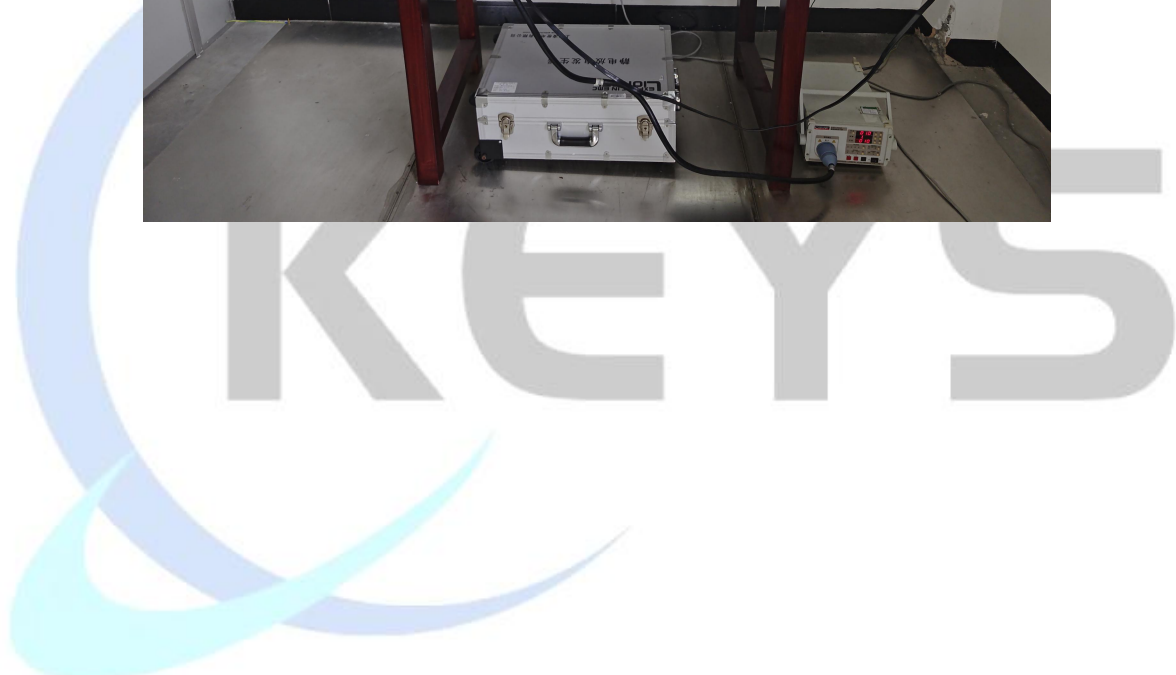
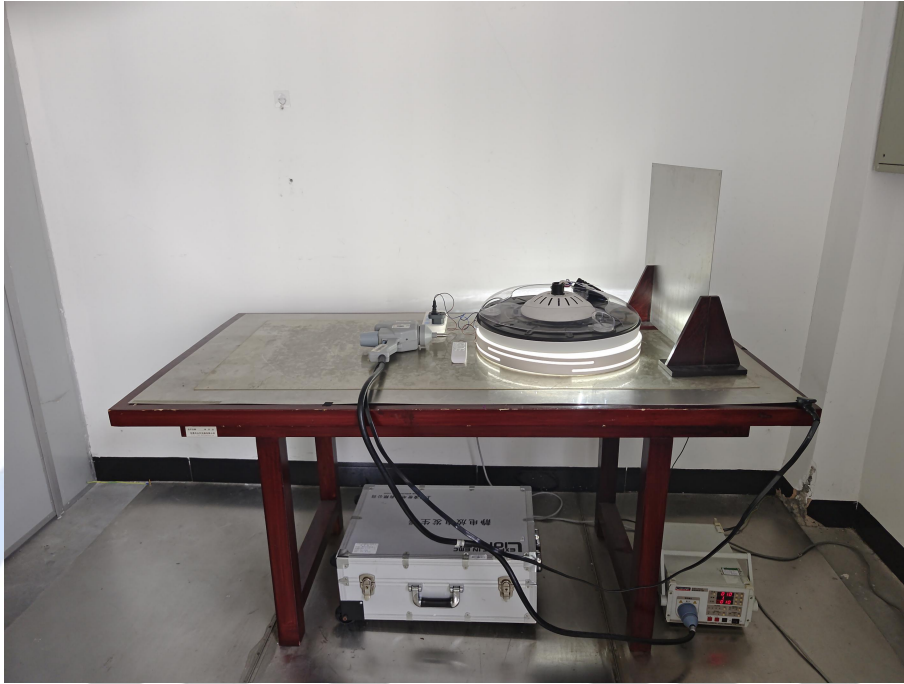

10. PHOTOGRAPHS OF EUT

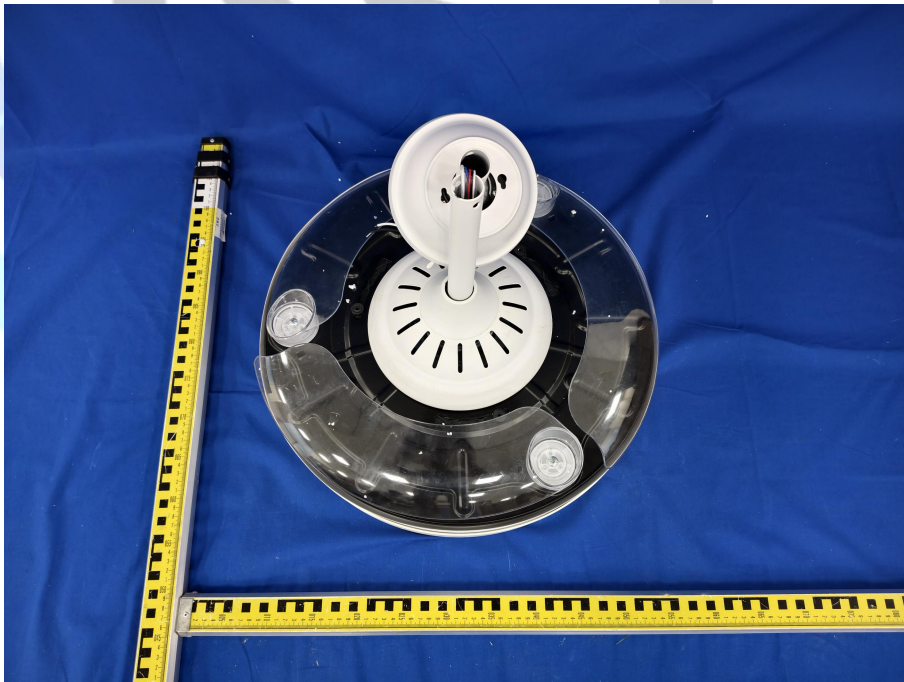
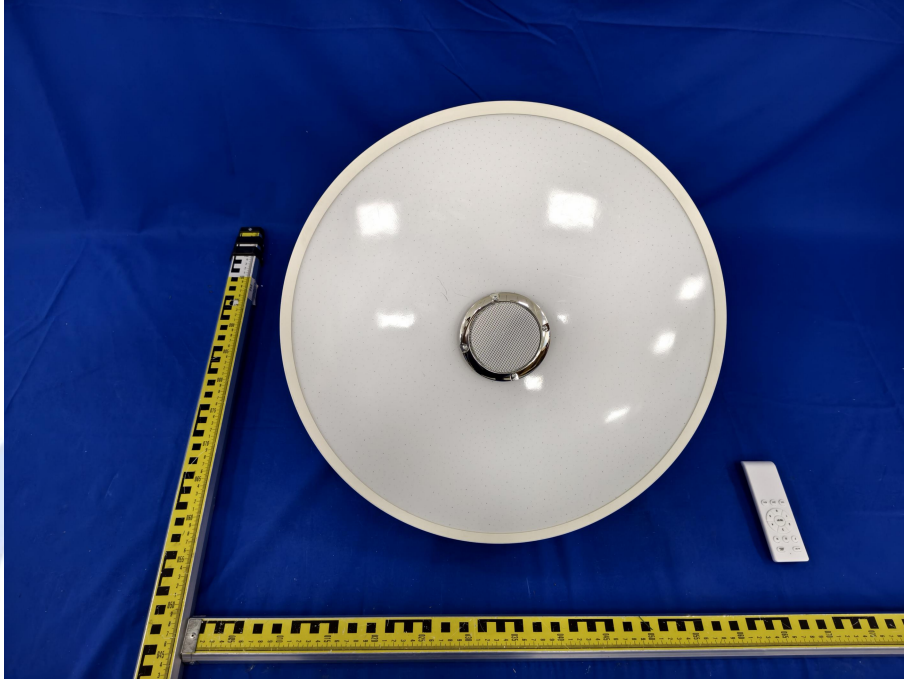

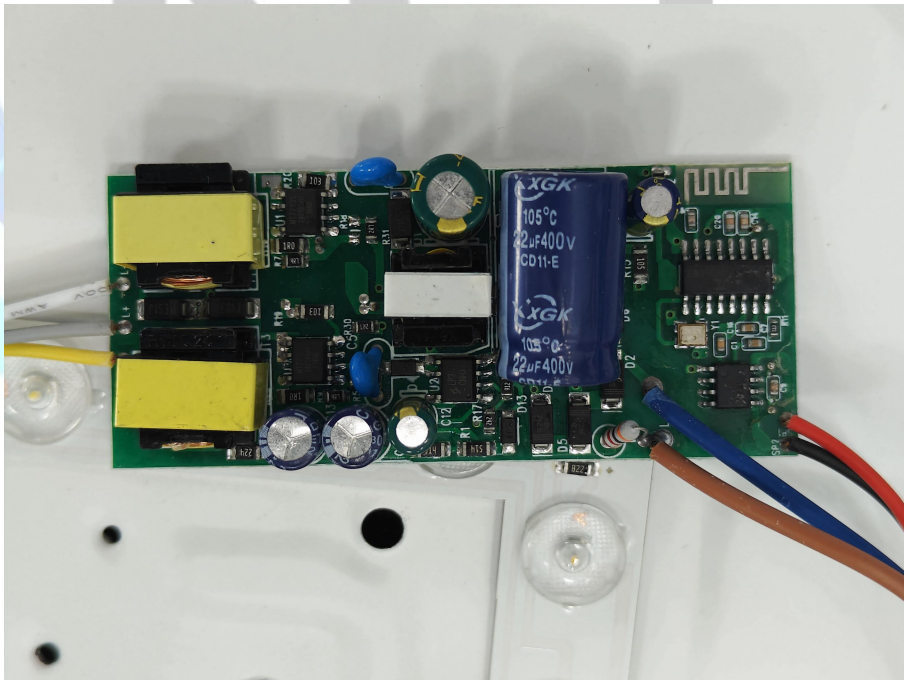
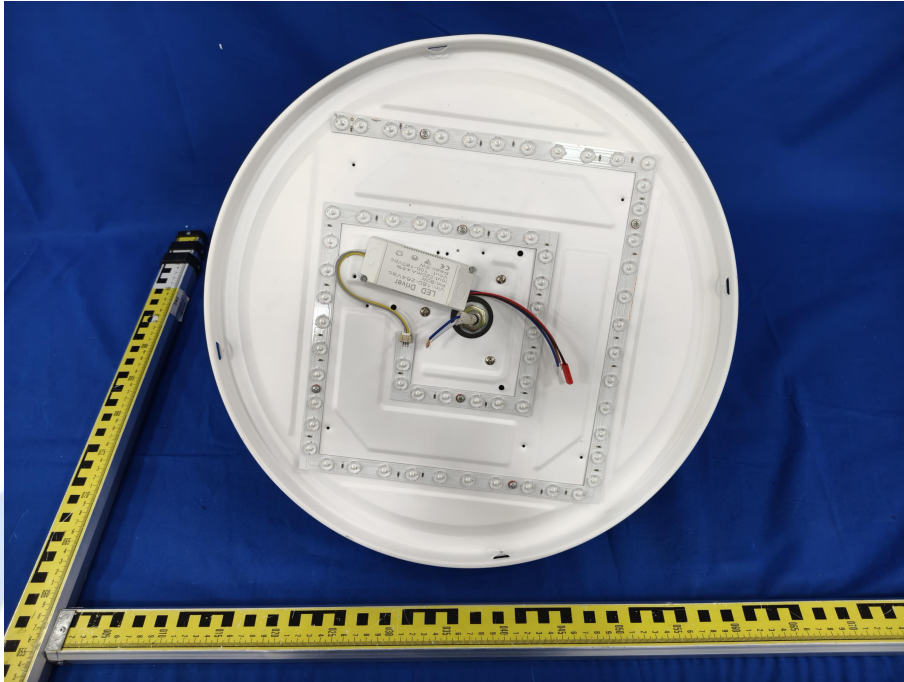

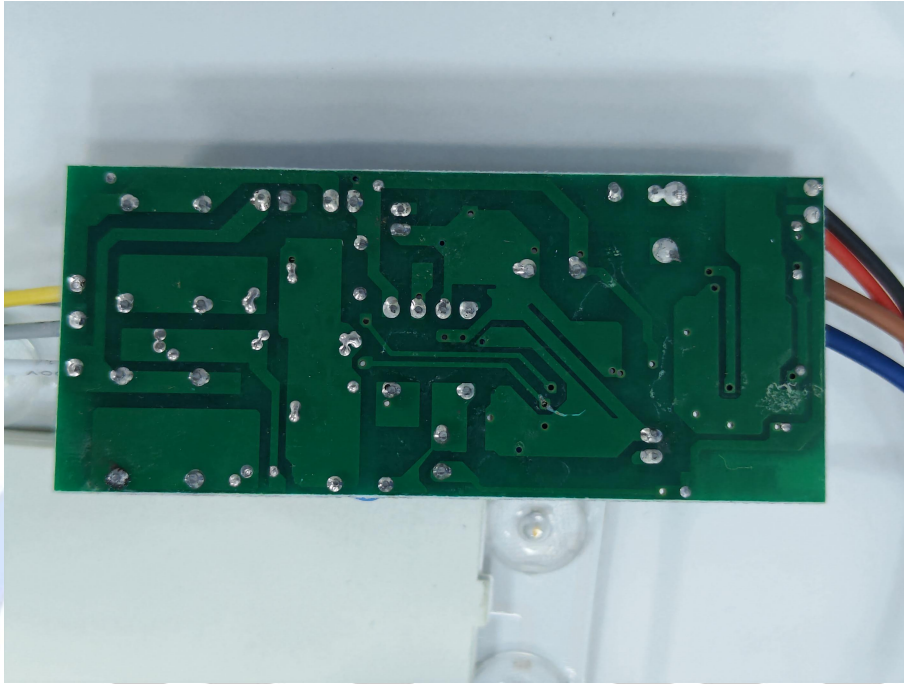

— End of report —